



ZERO KNOWS

C A R R Y I N G C A S E S



ZERO KNOWS... SOLUTIONS!

In practice, ZERO Manufacturing produces metal and plastic cases, containers and enclosures. But in truth, our products are protection solutions—ensuring the safe transport and viability of valuable equipment and electronics, without compromise.

Whether we meet your needs with one of our nearly 3,000 standard products, or with the infinite possibilities through a specialized custom design, ZERO has the engineering expertise and manufacturing experience to provide the perfect solution for your protection needs.

Please review the Carrying Case product data for specifications and information about how ZERO provides protection solutions for your industry.



ZERO
MANUFACTURING
PROTECTION

Quality Commitment

ZERO MANUFACTURING is committed to providing products and services that meet and exceed our customers' expectations. To that end, we have been ISO 9001 certified since 1994, are an SPC Certified Supplier and boast nearly a dozen Military Certifications. We have also received numerous awards and certifications from hundreds of customers and industries, both domestically and internationally.

ZERO MANUFACTURING, INC.

500 West 200 North, North Salt Lake, Utah 84054 USA

Toll Free US 800.500.9376 (ZERO) | Direct 801.298.5900 | Fax 801.299.7389

Email sales@zerocases.com | Web www.zerocases.com



ISO 9001:2008
AS9100 Rev. C
SPC Certified



TABLE OF CONTENTS

ZERO MANUFACTURING CAPABILITIES	2
CENTURION ELITE	6
ZEROLLER	7
Z100X Series Fixed Hinges	8
Z200X Series EMI/Environmental Protection	10
Z700X Series Separable Hinges	12
Modified Aluminum Cases	13
Options and Accessories	14
Foam Layer and Cushion Sets	18
MIL-SPEC	20
Watertight Series	20
Panel Options	22
VALULINE	32
ZC 7000 Series	33
ZIC 800 Series	34
ZIP 600 Series	36
ZIC 400 Series	37
Standard Hardware Options	38
GLOSSARY	39



©2013 COPYRIGHT OF ZERO MANUFACTURING, INC. ALL RIGHTS RESERVED. CENTURION IS A REGISTERED TRADEMARK, AND ELITE, STYLE-LITE, VALULINE AND ZEROLLER ARE TRADEMARKS OF ZERO MANUFACTURING, INC.

PRODUCTS AND SPECIFICATIONS ARE SUBJECT TO CHANGE. ZERO MANUFACTURING RESERVES THE RIGHT TO CHANGE, MODIFY AND/OR DISCONTINUE PRODUCTS, ACCESSORIES, SPECIFICATIONS, DIMENSIONS, HARDWARE, AND PRICING.

ZERO MANUFACTURING, INC. U.S. GOVERNMENT PROCUREMENT VENDOR CODE/CAGE ID NUMBER: 98376. ZERO MANUFACTURING, INC. IS ALSO THE SOURCE FOR DEEP DRAWN OR CASE ASSEMBLIES WITH THE FOLLOWING ID NUMBERS: 11357 M&M ELECTRONICS ENCLOSURES, 19178 ZERO EAST, 2J777 ZERO HALLIBURTON, 53031 TA CASE COMPANY, 76561 MOORLEE MANUFACTURING COMPANY, AND 94637 HALLIBURTON ENTERPRISES.

OUR BUSINESS

THE ZERO PROCESS Quality is the core philosophy guiding every step of our manufacturing process. From the initial product planning and engineering, through our certified inspection system, to the final performance of our products in the field, our time tested durability and unparalleled protection are the reasons we lead the industry in case fabrication and in metal and plastic enclosures.

We manufacture the most durable and innovative metal and plastic protective cases in the market. Our cases and enclosures are built to individual specifications, so you decide what you want and we build to suit your needs. ZERO's customized aluminum products provide ultimate protection with thousands of standard options and design capabilities from which to choose.



BENEFITS

BENEFITS OF ALUMINUM INSTRUMENT AND CARRYING CASES

HIGH STRENGTH-TO-WEIGHT RATIO

- ▶ Lightweight aluminum alloys used in ZERO cases are known for excellent strength in protecting equipment from damage.

EXTRAORDINARY RESISTANCE TO CORROSION

- ▶ Aluminum is highly resistant to nearly all substances that cause corrosion and weathering.

ENDURANCE AGAINST STRESS

- ▶ Including tears and cracks—Aluminum offers better fracture toughness than other materials, including resistance to both mechanical breakage and propagation of fractures.

SUSTAINING COLD TEMPERATURES

- ▶ Instead of becoming more fragile and brittle in cold weather, the tensile strength of ZERO aluminum cases increases with cold, without loss of ductility.

RFI/EMI SHIELDING AND ESD/GROUNDING

- ▶ Aluminum has the highest electrical conductivity-to-weight ratio of any metal, making ZERO cases excellent for RFI/EMI shielding and for ESD/grounding systems.
- ▶ Aluminum is an efficient reflector for externally generated interference, including the electromagnetic wavelengths of radio and radar.

HEAT DISSIPATION AND SHIELDING

- ▶ Aluminum is widely used in "heat sinks" and heat exchangers because of its high thermal conductivity. Used in an enclosure aluminum efficiently transports heat away from electronics and equipment.
- ▶ Has high reflectance to encroaching radiated heat, such as sunlight. (Aluminum has a light reflectivity of over 80%.)
- ▶ The low coefficient of Aluminum's thermal expansion allows it to sustain higher temperatures without distortion.

SPECIAL ENVIRONMENTS

- ▶ Aluminum is non-toxic, odorless, tasteless, non-absorbing, non-sparking, non-magnetic and resistant to fire.
- ▶ Aluminum cases can be used in a wide variety of special environments, including sanitary or clean rooms, food service areas and certain volatile environments.
- ▶ Aluminum provides excellent protective capabilities in environments requiring watertight, splash proof, drip proof and salt exposure specifications.

ADDITIONAL CUSTOMIZATION

- ▶ ZERO's aluminum products can be customized and modified without the cost of special molds.
- ▶ Drilling, laser cutting, riveting, welding, brazing, soldering, etc.
- ▶ ZERO can accommodate virtually every kind of finish, whether mechanical (such as brushing or polishing), chemical (anodizing) or an unlimited variety of finishes (paint and powder coatings).

CARRY CASE CHOICES

TOP OF THE LINE PROTECTION AND APPEARANCE FOR YOUR FINEST EQUIPMENT

KEY: • Indicates feature and/or option is available, but not necessarily standard. As case configuration and options may vary from customer to customer, please consult this catalog or ZERO for more specific details.

NOTE: For a complete list of plastic cases, containers, enclosures and solutions, request ZERO catalogs and/or data sheets, or visit www.zerocases.com for more information.

Please visit www.zerocases.com to view ZERO Manufacturing's complete product line and catalogs.



ISO 9001:2008 AS9100, REV C

ZERO is a certified company, and SPC certified supplier to major and key customers.

STANDARD CASE SELECTION GUIDE

PERFORMANCE	CENTURION MIL-Spec*	CENTURION ELITE	CENTURION VALULINE	STYLE-LITE
Lightweight	•	•	•	•
Watertight	•			
Splash Proof	•	•	•	
Drip Proof	•	•		
Salt Exposure	•			
Dust Proof	•			
RFI/EMI Shielded		•		
FCC Shielding Requirements	•	•		
Sustain Cold Temperatures	•	•	•	
Heat Dissipation	•	•	•	
MIL-STD-108	•			
OPTION EXAMPLES—ZERO has an extensive selection of options and accessories.				
Inner Panel	•	•	•	•
Panel Brackets		•	•	•
Separable Hinges	•	•	•	•
Casters or Rollers	•	•	•	•
CUSTOMIZATION—ZERO offers a wide selection of finishes, cushioning and more.				
Secondary Operations	•	•	•	•
Fast Turnaround Modifications	•	•	•	•
Protection From Drip, Salt, Splash		•	•	•

MILITARY SPECIFICATIONS

ZERO's processes and products are in accordance with current national and international standards. Successful development and testing includes the following military specifications:

- MIL-I-45208A
- MIL-PRF-28800
- SAE-AMS-STD-1595A
- SAE-AMS-2770
- SAE-AMS-W-6858
- MIL-STD-171D
- MIL-DTL-53072
- MIL-STD-108
- MIL-STD-810
- MIL-STD-130
- SAE-AMS-STD-2219 (Class A and B)
- MIL-STD-45662
- MIL-DTL-14072
- MIL-DTL-5541
- MIL-A-8625

CONTACT ZERO

NEED A QUOTE? Have any questions? Want to learn more? Contact ZERO.

800.500.9376

OUR CAPABILITIES

ZERO MANUFACTURING is the leader in the manufacture of quality, deep drawn and fabricated cases and enclosures. Offering over 5,800 pre-tooled sizes of deep drawn enclosures that enable us to build over 32,000 different sizes of deep drawn enclosures, and virtually unlimited sizes and configurations, ZERO is the source for secondary operations and customization, whether commercial or military specification.



DEEP DRAW

- ▶ Presses: Eleven (11) Presses
- ▶ Capacity Range: Up to a 440 ton fully CNC controlled press with quick die change capability
- ▶ Maximum Bed Size: 60" x 98"
- ▶ Maximum Drawn Depth: 18"
- ▶ Sizes: In addition to being able to build over 32,000 different sizes of deep drawn enclosures, we can create tooling customized to meet your specific requirements.
- ▶ Shears: Blanks are cut on automatic coil shears or conventional 12 foot shears using the waterjet for sheet stock.
- ▶ Certified to meet MIL-H-6088 and customer specifications AMS-2770.



SHEET METAL FABRICATION

- ▶ Press Brakes: Five press brakes up to 130 tons, equipped with back gauging
- ▶ Metal Fabricator: Two turret fabricators with 58 stations
- ▶ Punch Presses: Fifty-four mechanical punch presses up to 350 ton capacity, including a CNC Tru-Punch metal fabricator
- ▶ Extrusion Forming: Three heavy-duty and two light-duty benders for forming extrusions
- ▶ Degrease and Washer System: Automatic titrating conveyor system 6'w x 3'h maximum product size.
- ▶ Two (2) Tumbler Deburr Machines:
- ▶ 39 cu.ft Tumbler Deburr System – Capable of tumbling parts 16" corner to corner
- ▶ 10 cu.ft Tumbler Deburr System – Capable of Tumbling parts 4" corner to corner
- ▶ Shears: Three shears, 12 feet wide, with 10 gauge capacity and digital back gauging
- ▶ Fadal VMC 4th Axis Vertical Milling Machine
- Washer System: Automatic titrating conveyor system 6' x 90"
- ▶ Etch: Weld prep and cleaning
- ▶ Chemical Film: Certified to meet MIL-C-5541, Classes 1A and 3
- ▶ Powder King High Intensity Blender
- ▶ Hammond-Roto-Finish 39 cubic ft Vibratory Tumbler (2)
- ▶ Shears: Three shears, 12 feet wide, with 10 gauge capacity, digital back gauging
- ▶ Fadal VMC 4th Axis Vertical Milling Machine



LASER CUTTING

- ▶ Five-Axis Laser: Computer controlled five-axis laser provides flexibility, speed and efficiency to design and manufacturing capabilities, and the ability to custom cut and fabricate aluminum or other metals Bypassing the entire tooling process eliminates costly setup and tooling fees It's ideal for creating prototypes and for shorter runs
- ▶ Specifications: Working Range
X, Y, Z, C, B:
X = 158, 118, 80, 50"
Y = 60"
C = 360° Endless
B ± 120°
- ▶ Speed X, Y, Z, C, B:
X, Y = 2000 IPM
Z = 1200 IPM
C, B = 360°/sec
- ▶ Smallest Programmable Increment: 0.0039"
- ▶ Position Accuracy: 00039"
- ▶ Repeatability: Ps 00012"
- ▶ Working Height: 28"
- ▶ Anodizing to MIL-A-8625 Type III Class 2 Color and Clear Anodize coatings
- ▶ Standard and Custom colors available
- ▶ Max Envelope is 7' x 2' x 6'

PROCESSES

- ▶ Washer System: Automatic titrating conveyor system 6' x 90"
- ▶ Etch: Weld prep and cleaning
- ▶ Chemical Film: Certified to meet MIL-C-5541, Classes 1A and 3
- ▶ Powder King High Intensity Blender
- ▶ Hammond-Roto-Finish 39 cubic ft
- ▶ Vibratory Tumbler (2)

WATERJET

- ▶ 3 Axis Water Jet – 60000 psi, 6' x 13' x 8" Cutting Window

ENVIRONMENTAL TESTING

- ▶ Three test tanks to test for watertight integrity per MIL-STD-108
- ▶ Testing Lab: Drop, G-force and Load capacity
- ▶ Three test tanks to test for watertight integrity per MIL-STD-108.
- ▶ Tank opening: 5.5' x 2.5' x 5'

OUR CAPABILITIES



WELDING

- ▶ Welding performed IAW MIL-STD-2219 Class B & C (Class A by contract only) and certified to MIL-STD-1595.
- ▶ Resistance: Twelve 3-phase spot welders with Class A solid state controls rated up to 250 KVA. This permits spot welding aluminum up to 5/16" thick. Certified to MIL-W-6858D.
- ▶ Fusion: Eight 300 amp GTAW stations, 2 GMA welders, and longitudinal and peripheral seam welders.

ASSEMBLY

- ▶ Equipment: A wide range of electrical and pneumatic hopper fed riveters and versatile presses for threaded insert and stud installation. Conventional pedestal and hand held riveters are also used as well.

PAINTING

The ZERO paint system was custom designed to accommodate all enclosure products and types of paint. The primary system is completely enclosed and supplied with a 100,000 cfm filtered, climate controlled air make-up system.

Layout: A 540 foot overhead conveyor runs through five alternatively opposed filter booths and a 60 foot long paint drying oven. Oven is also equipped with a six foot wide lower conveyor to handle large and/or heavy objects.

Additional: Two off-line booths, and a third booth with two batch drying ovens for short runs. Liquid and powder painting and drying on separate lines.

Custom colors and finishes including PMS, RAL, and Fed-Std-595; silkscreen, markings, embossing, debossing, and more.

- ▶ Aluminum anodizing
- ▶ Chemical (Chem-Film) conversion coating
- ▶ Certification: Capable of painting to all specifications meeting safe environmental conditions. Enamel, water-base, and powder paints available and others as specified.

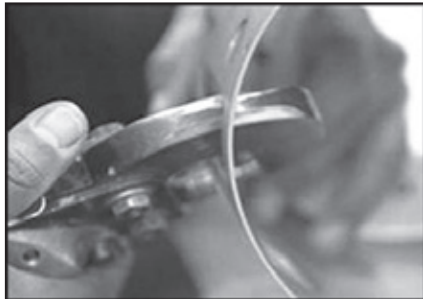

TOOL DEPARTMENT

ZERO Manufacturing, Inc. has a 9,600 square foot tool and die, and production machine shop with over 40 pieces of primary equipment. A foundry for casting sleeves for multiple draw jobs is also in-house. Production machining is performed on two CNC milling machines. Quality control is monitored by a coordinate measuring machine and a profile projector.

STANDARDS

- ▶ SO 9001 certified since 1994 and currently has ISO 9001:2008/9100 Rev C; water treatment facility, material and product testing lab, and analytical testing lab.

SPC certified supplier, RoHS compliant, 5S Process, Drum-Buffer-Rope production planning and control, and a green manufacturer.

ENGINEERING DEPARTMENT

- ▶ Manufacturing engineering is performed on the latest computer network system.
- ▶ Thirteen CAD-based design stations running Solidworks and Key Creator, Standard File Formats Including; ACIS, CKD, DXF, DWG, IGS, JPG, PDF, Parasolid, SAT, STEP, STL and TIF. Custom design capabilities to meet military or unique commercial specifications. Stress analysis can be performed on Solidworks upon request.

INSPECTION CAPABILITIES

- ▶ Key Equipment includes:
 - Mitutoyo Model 9106 Coordinate Measuring Machine
 - Helmel Check Master Coordinate Measuring Machine
 - Olympus Magna Mike Ultrasonic Thickness Gage

- Mitutoyo Digital Optical Comparator
- Various Mitutoyo Digital Height Gages
- Milli-Ohm Meter
- Spectrometer
- Multiple Surface Plates, indicators, micrometers, calipers and other hand held inspection tools

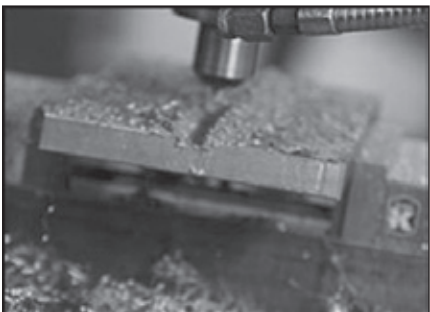

ADDITIONAL FACTS

- ▶ Plant Size: 286,000 square feet
- ▶ Manufacturing: 250,000 square feet
- ▶ Sample Plan: Based on MIL-STD-105, Level II
- ▶ Water Filtration System: All process lines are integrated with a reverse osmosis filtrations system. Over 80 percent of the industrial waste stream is recovered for purification and recycling.

CENTURION® ELITE

DISTINCTIVE ALUMINUM CASES

- ▶ TOP-OF-THE-LINE
- ▶ QUALITY AND STYLE
- ▶ HIGH STRENGTH
- ▶ LIGHTWEIGHT

CLEAN, SIMPLE LINES CHARACTERIZE THESE UNIQUE CARRYING CASES

The seamless, clean surfaces of the deep drawn aluminum case shells, accented by their distinctive styling beads, are now available in either a clear anodized finish which highlights the natural beauty of satin-anodized aluminum, or in a textured black powder paint finish.

The strength and durability of these cases are field proven in actual use—worldwide.

- ▶ Dust and weather resistant.
- ▶ Strong enough to stand on, thanks to specially heat-treated shells; and, even the largest case weighs only 17 pounds.

IMPRESSIVE PERFORMANCE

- ▶ Ultimate in appearance, reliability and versatility.
- ▶ Positive-locking latches assure secure closing, while complementing the case's clean styling.
- ▶ Fully-gasketed tongue-and-groove closure extrusion, mechanically formed.
- ▶ Sealed case integrity while permitting installation of adjustable panel support brackets (optional).
- ▶ Significant cost savings over other design methods of attaching angles for panel-mounted equipment.
- ▶ Blank panels available for all cases by special order.



CENTURION® ELITE FEATURES

- ▶ **CASE SHELL** Deep drawn aluminum alloy, heat treated.
- ▶ **CLOSURE** Interlocking tongue and groove extrusion of 6063-T5 aluminum alloy, mechanically formed and compressed to case shell. Lower closure accepts panel support brackets for Z100X, Z200X and Z700X Series.
- ▶ **FEET** Aluminum—riveted to case.
- ▶ **FINISH**
 - Silver Satin anodized (sulfuric acid) on all exposed surfaces.
 - Black powder paint interior and exterior (Z100X and Z700X Series).
- ▶ **HANDLE** Gray injection molded acrylic based multi-polymers. Maximum carry weight 60 lbs.
- ▶ **SEAL** Elastomeric neoprene gasketed seal.
- ▶ **LOCK**
 - Z100X: Combination Lock
 - Z700X: Combination Lock
 - Z200X: Keyed Latch
- ▶ **HINGE**
 - Z100X: Continuous-type aluminum with stainless steel pin riveted to case.
 - Z200X & Z700X: Two (2) separable hinge assemblies, nickel plated stainless steel riveted to case.
- ▶ **LATCHES**
 - Z100X: Two positive locking pull-down type, chrome plated.
 - Z700X: Two positive locking pull-down type, chrome plated.
 - Z200X: One keyed latch, one pull-down type, chrome plated.
- ▶ **ZERO** brand nameplate mounted on upper case shell.
- ▶ **TOLERANCE** ± 0.06"
- ▶ **ZEROLLER WHEELED CASE**
Please see page 7.

GUIDE

CENTURION ELITE

SERIES	FEATURE/FUNCTION	PAGE
ZEROLLER	Roller/Wheeled	7
Z100X	Standard Case	8-9
Z200X	EMI/Environmental	10-11
Z700X	Separable Hinges	12
MODIFIED	Sizes, Options, Hardware	13-15



THE WHEELED INDUSTRIAL CASE

Tired of carrying that case filled with instruments, tools or sales samples? The answer is ZeRoller™ for distinguished portability and convenience.

ZeRoller combines the ultimate carrying case with a rolling system engineered to make transport as easy as possible.

The roller system is mounted externally so there is very little intrusion on the inside of the case.

Case dimensions meet allowable cabin/carry-on luggage sizes.



ZEROLLER SYSTEM FEATURES

Handle	Telescoping plastic handle, push-button locking system
Wheels	High quality rubber with ball bearings.
Housing	Constructed of high-impact resistant plastics.
Interior Options	Layered Foam: Order using part number ZP21745-1 for Z105ZRX or ZP21745-3 for Z107ZRX

CASE NUMBERS & DIMENSIONS

Case No.	Exterior Width	Exterior Length	Interior Height	Upper Shell Interior Height	Lower Shell Interior Height	Material Thickness	Approx. Weight
Z105ZRX-SI/ON	13.00	21.00	6.50	2.75	3.75	0.040	8.7
Z107ZRX-SI/ON	13.00	21.00	7.50	3.75	3.75	0.040	8.9

Note: Measurements shown in inches. Weight shown in pounds. Price and delivery available by calling the ZERO Stock Sales Department.
SI = Silver Clear Anodized ON = Black Onyx Powder Coat Paint

CENTURION® ELITE

Z100X SERIES STANDARD FIXED HINGE CASES

- ▶ Select from 25 standard sizes.
- ▶ Constructed of durable aluminum alloy.
- ▶ Select from 2 standard finishes.
 - Silver Anodized, or Onyx Black Powder textured paint finish.
- ▶ Equipped with: Triple Digit Combination Lock, and Fixed Hinge
- ▶ Fixed Hinge and depending on case size, 1 or 2 lid stay arms
- ▶ Just add your equipment and go!

See Page 9 for complete dimensions and weights.

ACCESSORIES/OPTIONS

- ▶ PANEL—Panel dimensions and drawing specifications—See Table 2, page 9.
- ▶ BRACKETS—See page 9 for drawing, part number and installation instructions.
- ▶ CASTER KIT—available only on case numbers Z109X, Z110X and Z129X.



All sizes not shown

▶ ORDER Z100X CASES, FINISH, PANEL AND BRACKETS

Order by Part Number for each item: Case, Finish, Panel and/or Brackets

Z100X Case: _____ - _____ Color/Finish = SI Silver Clear Anodized
 Example: Z101X-SI ON Onyx Black Powder Paint

Z100X Panel: ZP108000-_____ See Page 8, Table 2

Z100X Brackets: ZP20653-1 _____ Specify Quantity

Note: See Page 19 for ordering Foam Cushion Sets.

▶ ORDER CUSTOM SIZES

Call Toll Free 800.959.5050



PANEL BRACKET OPTION

Case shown with optional panel support brackets.



UNPARALLELED PROTECTION

quotes@zerocases.com | www.zerocases.com

Fax 801.415.1771 | Direct 801.299.5978

TABLE 1

Z100X SERIES CASES Standard Fixed Hinge							SILVER	ONYX		
EXTERIOR		INTERIOR TOTAL HEIGHT	UPPER SHELL INTERIOR HEIGHT H ¹	LOWER SHELL INTERIOR HEIGHT H ²	MATERIAL THICKNESS	NET WEIGHT lbs	CASE MODEL	STOCK	CASE MODEL	STOCK
A WIDTH	B LENGTH									
8.50	19.75	14.49	1.20	13.29	0.051	8.10	•Z132X-SI	♦	•Z132X-ON	♦
9.00	12.00	5.00	2.00	3.00	0.040	3.30	Z100X-SI	♦	Z100X-ON	♦
9.00	16.00	7.75	2.50	5.25	0.051	5.00	Z101X-SI	♦	Z101X-ON	♦
9.00	16.00	14.50	2.50	12.00	0.051	7.20	Z116X-SI	♦	Z116X-ON	♦
10.00	36.00	4.00	2.00	2.00	0.040	7.00	•Z128X-SI		•Z128X-ON	
10.00	48.50	4.00	2.00	2.00	0.040	9.20	•Z130X-SI		•Z130X-ON	
11.25	16.50	3.25	1.50	1.75	0.040	4.40	•Z138X-SI	♦	•Z138X-ON	
12.00	32.50	4.50	1.50	3.00	0.040	8.00	•Z140X-SI		•Z140X-ON	♦
13.00	18.00	4.50	2.00	2.50	0.040	5.00	Z102X-SI	♦	Z102X-ON	♦
13.00	18.00	6.00	2.50	3.50	0.040	5.40	Z103X-SI	♦	Z103X-ON	♦
13.00	18.00	3.50	1.50	2.00	0.040	5.00	•Z104X-SI	♦	•Z104X-ON	
13.00	21.00	6.50	2.75	3.75	0.040	6.10	Z105X-SI	♦	Z105X-ON	♦
13.00	21.00	7.50	3.75	3.75	0.040	6.30	Z107X-SI	♦	Z107X-ON	
13.00	26.50	7.00	3.00	4.00	0.051	7.20	•Z134X-SI	♦	•Z134X-ON	
13.58	18.58	7.00	3.00	4.00	0.040	5.70	•Z136X-SI	♦	•Z136X-ON	♦
17.00	18.00	12.00	2.00	10.00	0.040	8.60	Z114X-SI	♦	Z114X-ON	♦
17.00	21.00	7.50	3.00	4.50	0.051	8.40	Z106X-SI	♦	Z106X-ON	♦
18.00	24.00	7.00	3.00	4.00	0.051	9.50	Z111X-SI	♦	Z111X-ON	
18.00	24.00	8.00	3.50	4.50	0.051	10.00	Z112X-SI	♦	Z112X-ON	
18.00	24.00	8.50	4.00	4.50	0.051	10.00	Z113X-SI	♦	Z113X-ON	♦
18.00	26.00	8.44	3.75	4.69	0.051	10.70	Z109X-SI	♦	Z109X-ON	♦
18.00	26.00	8.94	4.25	4.69	0.051	10.80	Z110X-SI	♦	Z110X-ON	♦
18.00	26.00	10.25	3.25	7.00	0.063	14.30	—		•Z142X-ON	♦
19.10	50.35	6.25	2.25	4.00	0.051	17.30	•Z126X-SI	♦	•Z126X-ON	
20.00	29.00	9.82	4.91	4.91	0.051	13.80	•Z129X-SI	♦	•Z129X-ON	

BASIC SHELL DIMENSIONS AND CASE SPECIFICATIONS

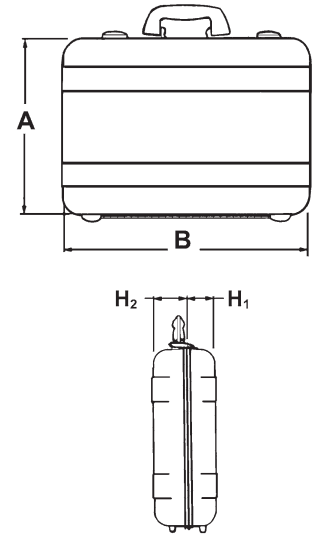

BRACKET

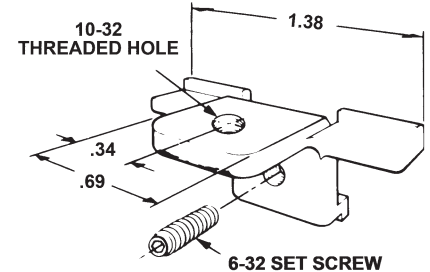

SEE PAGE 20 FOR ADDITIONAL DRAWINGS.

Measurements shown in inches. Non-stock cases require additional lead time. Price and delivery available upon request. Lower shell of model Z114X, Z116X and Z132X are complete with spot welded wrap-around riser section.
♦Bead configuration differs from illustration shown.

TABLE 2

Standard Instrument Panels

0.090" 6061-T6 Aluminum Alloy

CASE	A	B	RADIUS	PANEL NUMBER	CASE	A	B	RADIUS	PANEL NUMBER
Z100X	8.22	11.22	0.62	ZP108000-100	Z114X	16.22	17.22	0.84	ZP108000-114
Z101X	8.20	15.20	0.84	ZP108000-101	Z116X	8.20	15.20	0.84	ZP108000-116
Z102X	12.22	17.22	0.84	ZP108000-102	Z126X	18.30	49.55	1.59	ZP108000-126
Z103X	12.22	17.22	0.84	ZP108000-103	Z128X	9.22	35.22	0.84	ZP108000-128
Z104X	12.22	17.22	0.84	ZP108000-104	Z129X	19.20	28.20	0.84	ZP108000-129
Z105X	12.22	20.22	0.84	ZP108000-105	Z130X	9.22	47.72	0.84	ZP108000-130
Z106X	16.20	20.20	0.84	ZP108000-106	Z132X	7.70	18.95	0.84	ZP108000-132
Z107X	12.22	20.22	0.84	ZP108000-105					
Z109X	17.20	25.20	0.84	ZP108000-109	Z134X	12.20	25.70	0.84	ZP108000-134
Z110X	17.20	25.20	0.84	ZP108000-110	Z136X	12.80	17.80	0.84	ZP108000-136
Z111X	17.20	23.20	0.84	ZP108000-111	Z138X	10.47	15.72	0.84	ZP108000-138
Z112X	17.20	23.20	0.84	ZP108000-112	Z140X	11.22	31.72	0.84	ZP108000-140
Z113X	17.20	23.20	0.84	ZP108000-113	Z142X	17.17	25.17	0.59	ZP108000-142

Measurements shown in inches. For bracket drawing, part number and installation instructions, please see page 12.

TIP: INSTALLING A PANEL

Plan the panel in your case by checking dimensioning of closure extrusions.

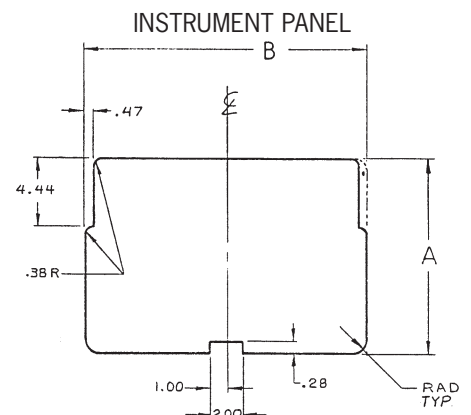

CENTURION® ELITE

Z200X SERIES EMI/ENVIRONMENTAL PROTECTION

TAKE A SIGNIFICANT STEP FORWARD WITH EMI SHIELDED CARRYING CASES

- ▶ Provides a minimum of 45 dB protection—30MHz to 1GHz.
- ▶ Secure, yet economical solution to shielding problems often encountered in portable applications.
- ▶ Keyed Latch
- ▶ Available in many standard sizes, for a variety of applications.
- ▶ Equipped with separable hinges.



TABLE 1

Z200X SERIES CASES EMI/Environmental Protection								STOCK
EXTERIOR A WIDTH	B LENGTH	INTERIOR TOTAL HEIGHT	UPPER SHELL INTERIOR HEIGHT H ¹	LOWER SHELL INTERIOR HEIGHT H ²	MATERIAL THICKNESS	NET WEIGHT LBS	CASE MODEL	
9.00	12.00	5.00	2.00	3.00	0.040	3.3	Z200X	◆
9.00	16.00	7.75	2.50	5.25	0.051	5.0	Z201X	◆
12.00	32.50	4.50	1.50	3.00	0.040	8.0	Z240X*	
13.00	18.00	4.50	2.00	2.50	0.040	5.0	Z202X	◆
13.00	18.00	6.00	2.50	3.50	0.040	5.4	Z203X	◆
13.00	21.00	6.50	2.75	3.75	0.040	6.1	Z205X	◆
13.00	21.00	7.50	3.75	3.75	0.040	6.3	Z207X	◆
13.00	26.50	7.00	3.00	4.00	0.051	7.2	Z234X*	
13.58	18.58	7.00	3.00	4.00	0.040	5.7	Z236X*	
17.00	21.00	7.50	3.00	4.50	0.051	8.4	Z206X	◆
18.00	24.00	7.00	3.00	4.00	0.051	9.5	Z211X	
18.00	24.00	8.00	3.50	4.50	0.051	10.0	Z212X	
18.00	24.00	8.50	4.00	4.50	0.051	10.0	Z213X	
18.00	26.00	8.44	3.75	4.69	0.051	10.7	Z209X	
18.00	26.00	8.94	4.25	4.69	0.051	10.8	Z210X	
20.00	29.00	9.82	4.91	4.69	0.051	13.8	Z229X	◆

Measurements shown in inches.

*Bead configuration differs from illustration shown.

Important: If you are planning to install a panel in your case, please check dimensioning of closure extrusions (see Page 11, Section AA) for proper fit.

SHELL AND CASE DIMENSIONS

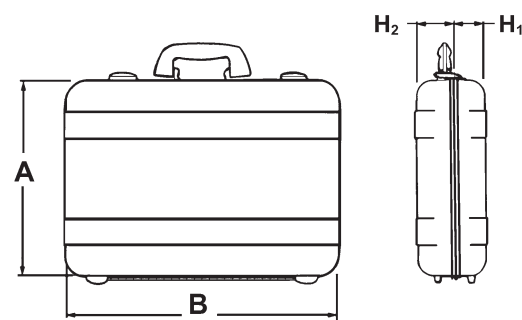

PANEL DIMENSIONS

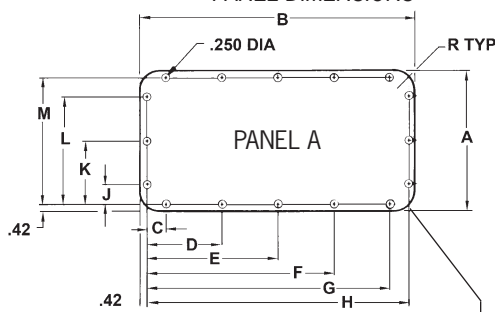

R TYP. = 1.09" Radius
Except Z200X Radius = 0.84"
Except Z242X Radius = 0.73"

TABLE 2

Standard Instrument Panels

0.125" 6061-T6 Aluminum Alloy, furnished with a Chemical Film Finish

CASE MODEL	ORDER PANEL	A	B	C	D	E	F	G	H	J	K	L	M	# OF HOLES
Z200X	- 1	8.52	11.52	2.340	-	-	-	18.340	10.680	1.580	-	6.080	17.660	8
Z201X	- 3	8.50	15.50	3.580	-	-	-	11.080	14.660	1.580	-	6.080	17.660	8
Z202X, Z203X	- 5	12.52	17.52	3.590	-	8.340	-	13.090	16.680	1.840	-	9.840	11.680	10
Z205X, Z207X	- 7	12.52	20.52	3.715	-	9.840	-	15.965	19.680	1.840	-	9.840	11.680	10
Z206X	- 9	16.50	20.50	3.715	-	9.840	-	15.965	19.680	1.830	7.830	13.830	15.660	12
Z209X, Z210X	- 11	17.50	25.50	1.580	8.705	-	15.955	23.080	24.660	1.580	8.330	15.080	16.660	14
Z211X, Z212X, Z213X	- 13	17.50	23.50	1.580	8.080	-	14.580	21.080	22.660	1.580	8.330	15.080	16.660	14
Z228X	- 17	9.52	35.52	1.590	9.465	17.340	25.215	33.090	34.680	1.590	-	7.090	8.680	14
Z229X	- 19	19.50	28.50	1.580	7.705	13.830	19.355	26.080	27.660	1.580	9.330	17.080	18.660	16
Z234X	- 29	12.50	26.00	1.625	8.928	-	16.231	23.535	25.160	1.830	-	9.830	11.660	12
Z236X	- 31	13.10	18.10	3.590	-	8.629	-	13.668	17.258	1.838	-	10.424	12.258	10
Z240X	- 33	11.52	32.02	1.590	8.840	15.590	22.340	29.590	31.180	1.715	-	8.965	10.680	14
Z242X	- 35	17.46	25.46	1.560	8.726	-	15.896	23.060	24.620	1.580	8.310	15.040	16.620	14

CENTURION® ELITE

Z200X SERIES EMI/ENVIRONMENTAL PROTECTION

ZERO ENGINEERS DEVELOP FLEXIBLE CASE SOLUTIONS

ZERO's Design Engineers have developed an optional environmentally sealed mounting panel.

- ▶ Utilizes same closure system as EMI version.
- ▶ Permits operation of an open case in field portable situations without damage to internal components and circuits.

Contact ZERO Design and Engineering for assistance, questions and expertise.

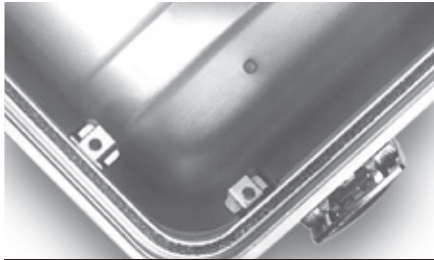

EMI GASKET OPTION

Z200X Series Case shown with optional Panel Support Brackets and EMI Gasket.



PANEL BRACKETS OPTION

Z200X Series Case shown with optional Panel installed.

CERTIFIED INDEPENDENT TESTING

ZERO's Centurion® Elite Z200X Series Cases have been tested by Chomerics, Inc., one of the nation's leading independent laboratories specializing in EMI/RFI emissions testing.

For additional information, please contact ZERO or your representative.

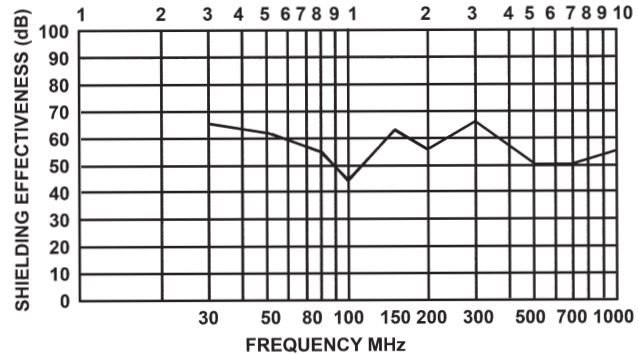

ORDER CENTURION ELITE Z200X CASES WITH GASKET, PANEL AND BRACKETS

Order by Part Number for each item (Case, Panel and/or Brackets)

Z200X Case with Gasket

Case _____ - _____ Select W = Weather Gasket or E = EMI Gasket
CASE NUMBER GASKET

Example: Z201X - W Model Z201X Case with Weather Gasket

Z200X Panel: ZP20568 - _____ See Table 2 on Page 10

Example: ZP20568 - 3

Z200X Brackets: ZP20654 - 1 _____ Specify Quantity

Call Toll Free 800.959.5050

Direct 801.299.5978 Fax 801.415.1771

Email sales@ZEROCases.com Web www.ZEROCases.com

BRACKET FOR Z200X SERIES

OPTIONAL
PANEL SUPPORT BRACKET
PART #ZP20654

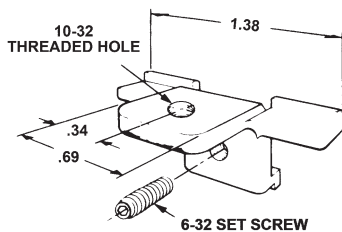

SECTION AA Z200X
SERIES

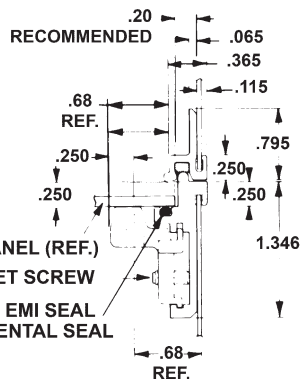

BRACKET INSTALLATION INSTRUCTIONS

1. Insert Bracket into Extrusion.
2. Rotate downward until Support Bracket is seated.
3. Slide Bracket laterally to align Bracket with Panel.
4. Tighten Set Screw.

Caution:
Do Not Over Tighten!

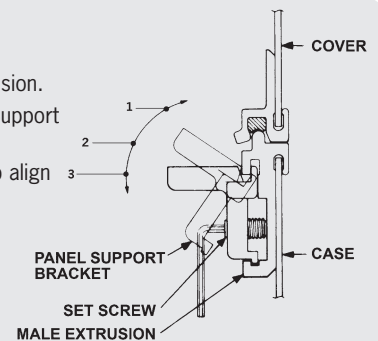

CENTURION® ELITE

Z700X SERIES SEPARABLE HINGE FEATURE

Separable hinges allow cover to be removed easily to separate upper and lower shells, and to pivot shells in for a unique open case mode for your equipment.



TABLE 1

Z700X SERIES CASES Separable Hinges									SILVER	ONYX		
EXTERIOR		INTERIOR TOTALS**			INTERIOR SHELL HEIGHT		MATERIAL THICKNESS	NET WEIGHT LBS	CASE MODEL	STOCK	CASE MODEL	STOCK
A WIDTH	B LENGTH	HEIGHT	WIDTH	LENGTH	UPPER H1	LOWER H2						
9.00	12.00	5.00	8.92	11.92	2.00	3.00	0.040	3.3	Z700X-SI	♦	Z700X-ON	♦
9.00	16.00	7.75	8.90	15.90	2.50	5.25	0.051	5.0	Z701X-SI	♦	Z701X-ON	♦
9.00	16.00	14.50	8.90	15.90	2.50	12.00	0.051	7.2	Z716X-SI		Z716X-ON	
11.25	16.50	3.25	11.17	16.42	1.50	1.75	0.040	4.4	Z738X-SI		Z738X-ON	
12.00	32.50	4.50	11.92	32.42	1.50	3.00	0.040	8.0	Z740X-SI		Z740X-ON	
13.00	18.00	4.50	12.92	17.92	2.00	2.50	0.040	5.0	Z702X-SI	♦	Z702X-ON	♦
13.00	18.00	6.00	12.92	17.92	2.50	3.50	0.040	5.4	Z703X-SI	♦	Z703X-ON	♦
13.00	18.00	3.00	12.92	17.92	1.50	2.00	0.040	10.8	Z704X-SI	♦	Z704X-ON	♦
13.00	21.00	6.50	12.92	20.92	2.75	3.75	0.040	5.0	Z705X-SI	♦	Z705X-ON	♦
13.00	21.00	7.50	12.92	20.92	3.75	3.75	0.040	6.3	Z707X-SI	♦	Z707X-ON	♦
13.00	26.50	7.00	12.90	26.40	3.00	4.00	0.051	7.2	Z734X-SI		Z734X-ON	
13.58	18.58	7.00	13.50	18.50	3.00	4.00	0.040	5.7	Z736X-SI		Z736X-ON	
17.00	18.00	12.00	16.92	17.92	2.00	10.00	0.040	8.6	Z714X-SI		Z714X-ON	
17.00	21.00	7.50	16.90	20.90	3.00	4.50	0.051	8.4	Z706X-SI	♦	Z706X-ON	♦
18.00	24.00	8.50	17.90	23.90	4.00	4.50	0.051	10.0	Z713X-SI		Z713X-ON	
18.00	26.00	8.50	17.90	25.90	3.75	4.69	0.051	10.7	Z709X-SI	♦	Z709X-ON	♦
18.00	26.00	9.00	17.90	25.90	4.25	4.69	0.051	10.8	Z710X-SI	♦	Z710X-ON	♦
18.00	26.00	10.25	17.88	25.88	3.25	7.00	0.063	14.3	—		Z742X-ON	
20.00	29.00	9.82	19.90	28.90	4.91	4.91	0.051	13.8	Z729X-SI		Z729X-ON	

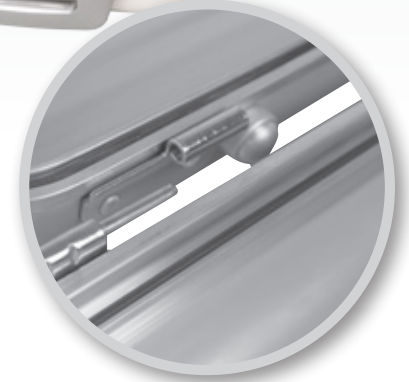

Closeup of Separable Hinge

TIP: INSTALL A PANEL

If you are planning to install a panel in your case, please check dimensioning of closure extrusions illustrated below.

Measurements shown in inches. Non-stock cases require additional lead time. Price and delivery available upon request. Lower shell of model Z114X, Z116X AND Z132X are complete with spot welded wrap-around riser section.

*Bead configuration differs from illustration shown below. Contact ZERO for detailed information.

**Total Interior Width and Length do not include closure inclusion.

BASIC SHELL DIMENSIONS AND CASE SPECIFICATIONS

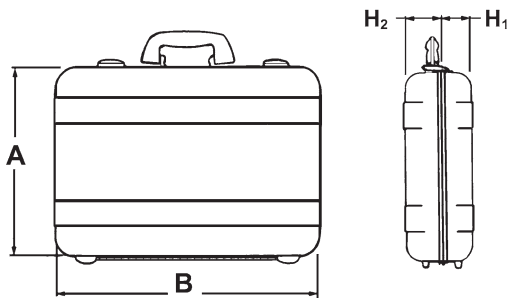

BRACKET FOR Z100X AND Z700X SERIES

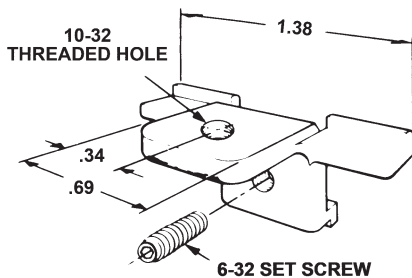
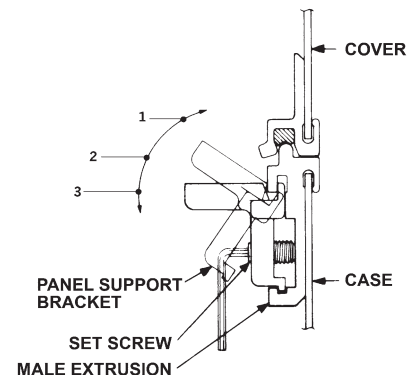
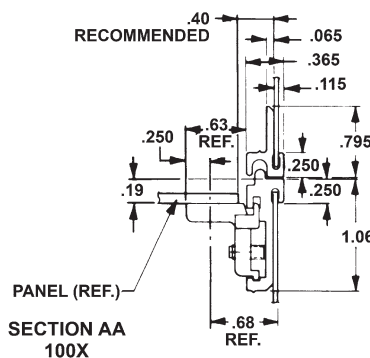

TABLE 2 Order Panels And Brackets for the Z700 Cases

Instrument Panels 0.090" 6061-T6 Aluminum Alloy

CASE	A	B	RADIUS	PANEL PART NUMBER	CASE	A	B	RADIUS	PANEL PART NUMBER
Z700X	8.22	11.22	0.62	ZP108000-100	Z713X	17.20	23.20	0.84	ZP108000-113
Z701X	8.20	15.20	0.84	ZP108000-101	Z714X	16.22	17.22	0.84	ZP108000-114
Z702X	12.22	17.22	0.84	ZP108000-102	Z716X	8.20	15.20	0.84	ZP108000-116
Z703X	12.22	17.22	0.84	ZP108000-103	Z729X	19.20	28.20	0.84	ZP108000-129
Z704X	12.22	17.22	0.84	ZP108000-104	Z734X	12.20	25.70	0.84	ZP108000-134
Z705X	12.22	20.22	0.84	ZP108000-105	Z736X	12.80	17.80	0.84	ZP108000-136
Z706X	16.20	20.20	0.84	ZP108000-106	Z738X	10.47	15.72	0.84	ZP108000-138
Z707X	12.22	20.22	0.84	ZP108000-107	Z740X	11.22	31.72	0.84	ZP108000-140
Z709X	17.20	25.20	0.84	ZP108000-109	Z742X	17.17	25.17	0.59	ZP108000-142
Z710X	17.20	25.20	0.84	ZP108000-110	—	—	—	—	—



CENTURION® ELITE

MODIFIED ALUMINUM CASES

CREATE ANY TYPE OF MODIFICATION TO CENTURION STANDARD ALUMINUM CASES

- ▶ Custom Cutouts
- ▶ Special Hole Patterns
- ▶ Accessory Brackets
- ▶ Related Operations

ZERO offers a variety of standard hardware options and customization on the following pages as a fast and efficient means for customized cases. Lead time and cost vary depending on the complexity.

Please consult ZERO's Design and Engineering department for design assistance.



KEYED LATCH STANDARD

- ▶ Z200X Series Cases are equipped with one keyed latch as standard equipment.

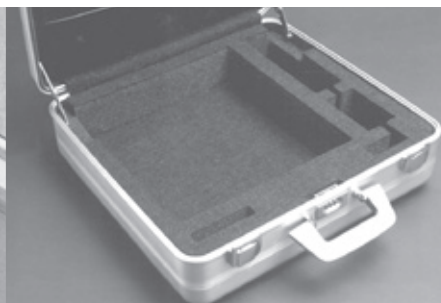

KEYED LATCH OPTION

- ▶ Z100X Series Cases for added security.
- ▶ Z200X Series Cases—Additional latches may be added.



KEY-ALIKE LOCKS OPTION

- ▶ Specify a common key for multiple case orders—using keyed-alike locks.
- ▶ Combination locks require special set-up and additional lead time.



MODIFIED OPTION

- ▶ Customize with cutouts, mounting holes, brackets and more.



INNER PANEL OPTION

Many more options are available.



Toll Free 800.959.5050
quotes@zerocases.com | www.zerocases.com
 Fax 801.415.1771 | Direct 801.299.5978

CENTURION® ELITE

MODIFIED ALUMINUM CASES



► EXTERIOR OPTIONS

In designing a modified Centurion Elite case, the following will need to be specified:

Base Case Number _____

Upper Shell Height, Interior _____

Lower Shell Height, Interior _____

FINISH

Options: Silver or Onyx Black Powder Paint (Standard)
 Anodize—Specify Color _____
 Custom Paint Color—Specify FED-STD-595
 Silk Screening
 Other—Specify _____

HINGE

Options: Fixed Piano/Continuous
 Separable—Two Assemblies (Page 16)

LOCK

Options: Combination
 Keylock, Assorted
 Keylock, Keyed Alike
 None

LATCH

Options: Standard Drawbolt
 Keyed Latch (Page 16)
 ZSP2-204 (Page 16)
 ZSP2-210 (Page 16)

HANDLE

Options: Standard Plastic
 ZSP20136 (Page 16)
 ZSP20137 (Page 16)

FOOT

Options: Aluminum
 Rubber ZSP7-718 (Page 16)

► INTERIOR OPTIONS

ZERO can equip your case with internal support brackets and panels to meet special equipment mounting requirements. Storage compartments and foam cushioning in sheet, convoluted or die cut foam are also available.

Substitutions, additions and/or deletions in latches, hinges, handles, lid stays, locks, type of finish or color can be handled, without delay, from an extensive inventory of accessory items (pages 24 and 25).

A complete range of secondary operations are readily available from ZERO's skilled, special fabrication departments. ZERO will quote any such requirements on request, and will build your case to your prints, or offer complete design assistance.

► INTERIOR REQUIREMENTS

FOAM

Options: Blank Layered Cushion Set (Page 18)
 Diced Layered Cushion Set (Page 18)
 Custom—Provide Drawings and/or Material
 Specifications _____

PANEL Single or Multiple

Options: Standard Inner Lid Assembly (Page 17)
 Standard Z100X or Z700X Series Panel (Page 17)
 Standard Z200X Series Panel (Page 19)
 Custom Panel—Specify _____
 Silk Screening

PANEL BRACKETS

Options: Standard Z100X Series ZP20653 (Page 20)
 Standard Z200X Series ZP20654 (Page 20)

GASKET

Options: Standard Neoprene (Page 14)
 EMI Shielded (E) (Page 18)
 Weather/Environmental (W) (Page 18)

Additional Requirements _____

TABLE 3 Basic Shell-Half Sizes and Dimensions Reference Drawings Below

CENTURION ELITE Modified Aluminum Cases

CASE NUMBER			EXTERIOR		C INTERIOR**		D	E	F	G	H	R ¹	R ²	R ³	R ⁴	L	MATERIAL THICKNESS
Fixed Hinge	EMI Shield	Separable Hinge	A Width † ±.06	B Length † ±.06	MIN	MAX											
*Z132	Z232	*Z732	8.50	19.75	1.20	2.75	-	-	-	-	-	1.25	0.50	-	0.50	2.5°	0.051
Z100	Z200	Z700	9.00	12.00	2.00	2.91	3.50	1.75	1.34	2.81	0.09	1.00	1.00	6.00	1.00	2.5°	0.040
Z101	Z201	Z701	9.00	16.00	2.00	5.16	5.50	1.75	1.34	2.81	0.09	1.25	1.00	6.00	1.00	2.5°	0.051
*Z128	-	*Z728	10.00	36.00	2.00	2.91	-	2.25	1.50	2.50	0.12	1.25	1.00	-	1.00	-	0.040
*Z130	-	*Z730	10.00	48.50	2.00	1.91	-	2.25	1.50	2.50	0.12	1.25	1.00	-	1.00	-	0.040
*Z138	-	*Z738	11.25	16.50	1.50	2.00	-	1.75	1.44	4.88	0.12	1.25	0.50	-	0.50	-	0.040
*Z140	Z240	*Z740	12.00	32.50	1.50	2.91	-	2.25	1.44	4.63	0.12	1.25	0.50	-	0.50	-	0.040
Z103	Z203	Z703	13.00	18.00	2.00	5.50	6.40	2.00	1.75	5.12	0.12	1.25	1.00	6.25	1.00	2.5°	0.040
*Z104	-	*Z704	13.00	18.00	1.50	1.91	-	2.25	1.50	5.50	0.09	1.25	0.50	-	0.50	-	0.040
Z105	Z205	Z705	13.00	21.00	2.00	3.66	7.90	2.00	2.00	5.00	0.12	1.25	1.00	6.25	1.00	2.5°	0.040
*Z134	Z234	*Z734	13.00	26.50	2.00	3.91	-	2.25	1.50	5.50	0.12	1.25	0.75	-	0.75	-	0.051
*Z136	Z236	*Z736	13.58	18.58	2.00	4.29	-	2.25	1.50	6.08	0.12	1.25	0.50	-	0.50	-	0.040
Z114	Z214	Z714	17.00	18.00	2.00	3.96	6.40	2.68	2.25	7.14	0.12	1.25	1.00	6.25	1.00	2.5°	0.040
Z106	Z206	Z706	17.00	21.00	2.25	4.41	7.46	2.68	2.25	7.13	0.12	1.25	1.25	6.50	1.25	2.5°	0.051
Z112	Z212	Z712	18.00	24.00	2.25	4.41	8.87	2.93	2.25	7.64	0.12	1.25	1.25	6.50	1.25	2.5°	0.051
Z109	Z209	Z709	18.00	26.00	2.37	4.60	9.81	2.93	2.25	7.64	0.12	1.25	1.25	6.50	1.25	2.5°	0.051
*Z142	-	*Z742	18.00	26.00	2.00	6.91	-	3.15	1.63	8.43	0.12	1.00	1.00	-	1.00	-	0.063
*Z126	-	*Z726	19.10	50.35	2.00	3.91	22.53	2.93	2.00	9.12	0.12	2.00	1.00	6.25	1.00	2.5°	0.051
Z129	Z229	Z729	20.00	29.00	2.25	4.82	11.31	2.94	2.25	9.62	0.12	1.25	1.25	6.50	1.25	2.5°	0.051

*Bead configuration differs from illustration shown below. Contact ZERO for detailed information.

**2" minimum H² depth with standard hardware. Measurements shown in inches.

BASIC SHELL DIMENSIONS AND CASE SPECIFICATIONS

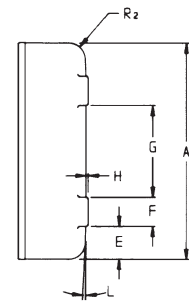
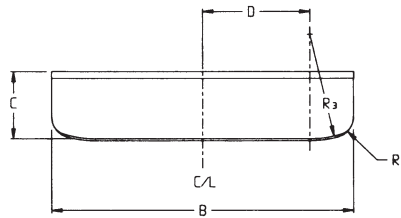
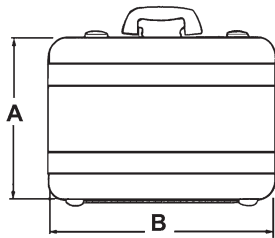

EXTRA HEIGHT CASES WITH RISERS

Cases in the standard Elite line can each be modified into an almost infinite combination of case heights, if required.

Table 3 (C Columns) shows the minimum/maximum height range of each shell.

► Any combination of dimensions may be ordered within the limits shown. If additional height is required, a riser section(s) can be added to the basic shells.

ZERO reserves the right to provide a riser section in either configuration (Section CC).

EXTRA HEIGHT CASES WITH RISERS (TYP.)

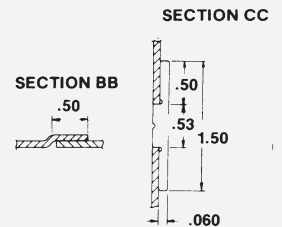
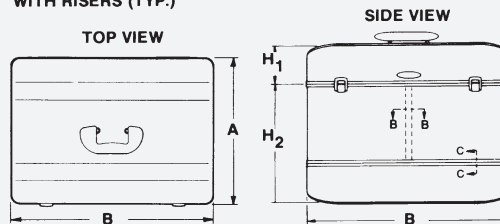

Z100X SERIES ONLY

► Gain extra height with the combination of extrusion and sheet metal wrap. Splice located at maximum draw depth.

► Silver Finish: Risered models (Z128X, Z129X and Z130X) are fine sanded and sulfuric acid anodized on all exposed surfaces.

CENTURION® ELITE

MODIFIED ALUMINUM CASES

Standard Hardware Options

HANDLES

PART #ZP20136

- ▶ MATERIAL: Steel Plate and Pull-Down Grip
Non-Rigid Synthetic Resin Composition
- ▶ WEIGHT: 0.43 lbs
- ▶ PERFORMANCE DATA: Design Load 100 lbs
Pull-Down Stops at 90° Open Position
Spring Returns to Pull-Down Position Shown

PART #ZP20137-1 (without holes)

PART #ZP20137-2 (with holes)

- ▶ MATERIAL: Aluminum Plate, Steel Pull-Down with Rubber Grip
- ▶ WEIGHT: 0.50 lbs
- ▶ PERFORMANCE DATA:
Spring Loaded, Rattle Proof
Carries at 90°
Designed to Lift 150 lbs

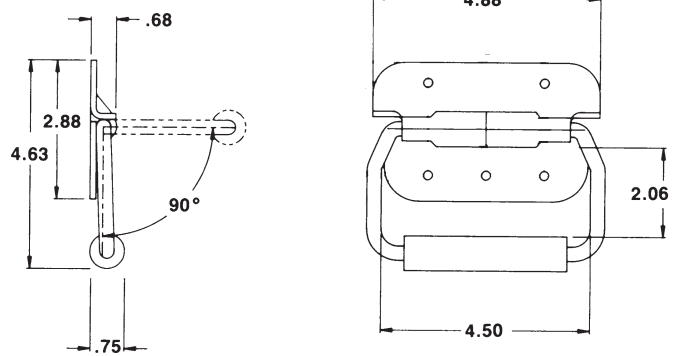
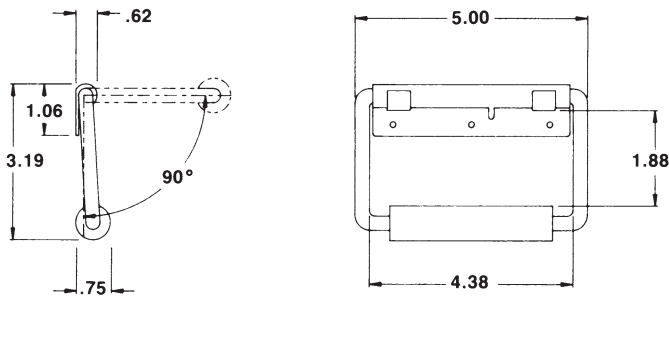

LATCHES

PART #HP25051-1

Keyed Latch

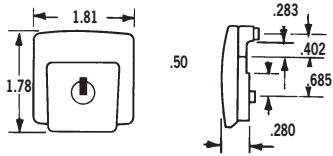

PART #ZSP2-204-1

- ▶ MATERIAL: Steel
- ▶ WEIGHT: 0.10 lbs
- ▶ PERFORMANCE DATA:
Preloaded to 70 lbs
Withstands 400 lbs Pull

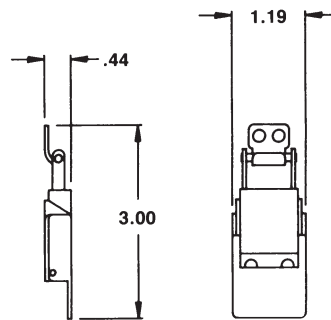

PART #ZSP2-210-1

- ▶ MATERIAL: Steel
- ▶ PERFORMANCE DATA:
Preloaded to 90 lbs
Withstands 300 lbs Pull

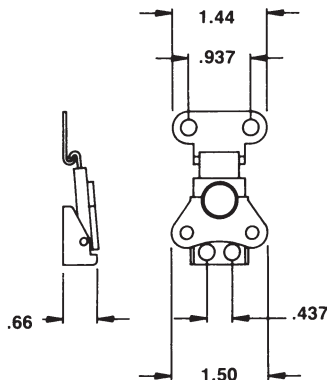

FEET

RUBBER FOOT
PART #ZSP7-718

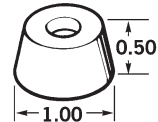

HINGE

- PART #ZP20281-1 Separable (long pin)
- PART #ZP20281-2 Separable (short pin)
- PART #ZP20282-3 Non-Separable
- ▶ MATERIAL: Stainless Steel, Nickel Plated
- ▶ WEIGHT: 0.104 lbs

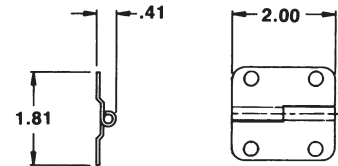

CENTURION® ELITE

MODIFIED ALUMINUM CASES

Standard Hardware Options

INNER LID ASSEMBLY

PART #HP25013

- ▶ MATERIAL: 6061-T6 Aluminum per QQ-A250/11 0.060" thick
- ▶ PERFORMANCE DATA: Push button latch is specially designed for use with arctic mittens. Card or book clips may be attached directly to lid. Lid is contoured to match radius of lid with reliefs cut in hinged edge to permit opening over 90°.

Note: Lowest possible position of lid is 0.69" above parting line. For non-standard location of Inner Lid assembly, please contact ZERO.

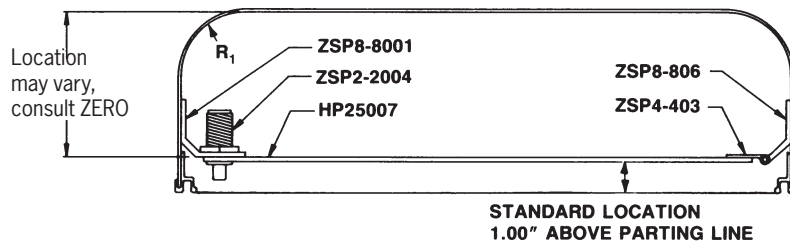

CARD CLIPS

PART #ZSP9-902

- ▶ MATERIAL: Spring Tempered Steel
- ▶ WEIGHT: 0.09 lbs
- ▶ PERFORMANCE DATA:
0.27 lbs Camping Force
When Deflected 0.06 inches

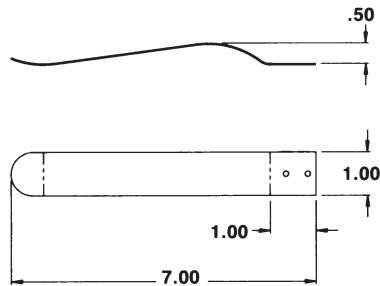

PART #ZSP9-903

- ▶ MATERIAL: Spring Tempered Steel
- ▶ WEIGHT: 0.04 lbs
- ▶ PERFORMANCE DATA:
0.27 lbs cCamping Force
When Deflected 0.06 inches

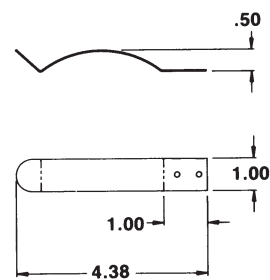

CONTACT US

NEED A QUOTE? Have any questions?

Want to learn more? Contact ZERO.

800.500.9376

CENTURION® ELITE

STANDARD FOAM CUSHION SETS

PROTECT FROM SHOCK AND VIBRATION

Blank layered foam cushion sets are available for every Centurion® Elite carrying case.

Diced layered foam packs are also available for select sizes.

All systems are available from stock, and offer a fast, economical answer to your equipment packaging requirements.



BLANK LAYERED CUSHION SET

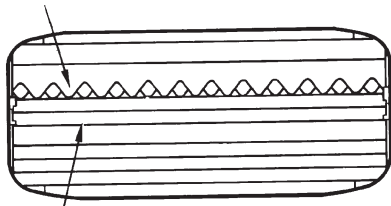

LAYERED FOAM
LAYER THICKNESSES WILL
VARY DEPENDING ON
MODEL NUMBER.

PART #M44784 Blank Layered
Foam Cushion Set

DICED LAYERED CUSHION SET

Remove blocks for desired
cavity, balance of cushion
remains intact.

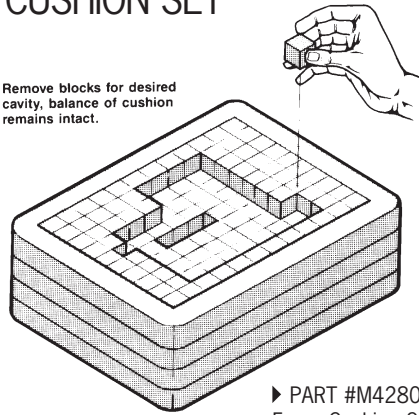

▶ PART #M42807 Diced Layered
Foam Cushion Set

GET A SNUG FIT

Protect your most delicate equipment by specifying PART #M44784 foam pack, made of Gray 1.6 lb pcf density, polyurethane foam, layered bottom and convoluted top.

Standard foam packs are available from stock to fit all standard Centurion® Elite cases.

Foam pack made of gray polyurethane foam 1.6 lb pcf density layered bottom and convoluted top.

Two of the bottom layers are blank foam and two layers are pre-cut squares. Remove blocks for the desired equipment cavity, the rest of the cushion remains intact.

Available for case numbers: Z100, Z102, Z103, Z105, Z106, Z110.

▶ ORDER LAYERED CUSHION SET

Blank Layered
Cushion Set — —

Case Model Number _____

SAMPLE PART NUMBER
M44784-101

▶ ORDER DICED CUSHION SET

Diced Layered
Cushion Set — —

Case Model Number _____

SAMPLE PART NUMBER
M42708-101

CENTURION® ELITE

STANDARD FOAM CUSHION SETS

An improperly packaged enclosure can damage contents. Dissipating the energy created by extreme shock or by continual vibration in-transit is a highly-specialized art which extends beyond traditional engineering calculations. Determining the best method for properly abate this potentially destructive energy is essential to extending product life.

ZERO has designed and fabricated over one million specialized carrying cases with vibration and shock isolation systems. Working with the most demanding customers in high technology business, military and our national space program, ZERO's Designers provide a wealth of specialized engineering knowledge and practical experience.

Contact ZERO for a free consultation to assist you on your next packaging requirement. We can design and recommend a system which satisfies your needs—saving you time and money.

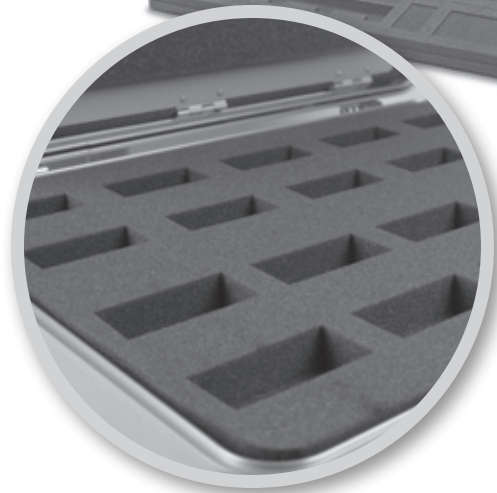
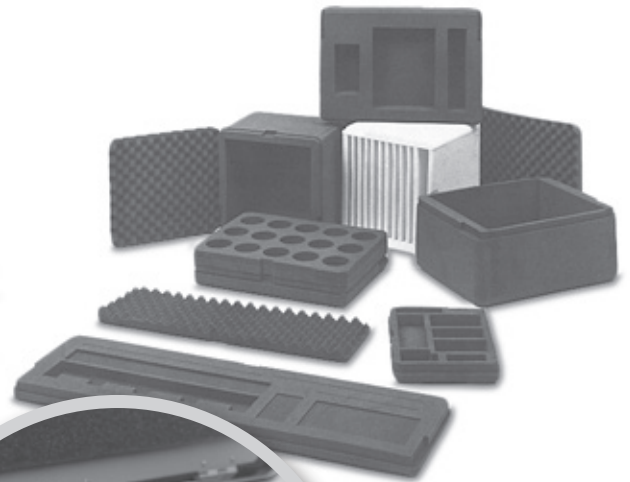

POLYURETHANE FOAM

- ▶ Low-cost cellular packaging material.
- ▶ Predictable and excellent performance characteristics.
- ▶ Broad temperature range (-10° to +185°F) performance.
- ▶ Most frequently used cushioning material in case packaging.
- ▶ Can be coated for added moisture and abrasion resistance.
- ▶ Ease of fabrication into a variety of shapes makes polyurethane foam especially adaptable for use as a multi-cavity cushion material.
- ▶ Available in flat sheet stock or it can be molded into any required shape.
- ▶ Various colors and densities are available; the most common is Gray in density selections of 1.6, 2 and 4 lb pcf.

POLYETHYLENE FOAM

- ▶ Low-cost closed cell packaging material.
- ▶ Predictable performance characteristics.
- ▶ Ability to withstand high bearing loads.
- ▶ Provides excellent protection against shock, vibration and shifting during handling and transport.
- ▶ Various colors and densities are available; the most common is Charcoal Gray in density selections of 1.7, 2 and 4 lb pcf.

ZERO'S ANTI-STATIC FOAM MINIMIZES STATIC CHARGE

Both Polyurethane and Polyethylene Foams in anti-static options provide quick, but controlled dissipation of electrostatic charges—properties important to your sensitive electronic instruments, parts and products.

CENTURION® MIL-Spec

WATERTIGHT CARRYING CASES TO MIL-STD-108*

The watertight Centurion® MIL-Spec Series from ZERO Manufacturing, Inc. features deep-drawn heat-treated aluminum case shells with wrinkle-free surfaces, accented by distinctive styling beads. Sturdy and durable. Centurion MIL-Spec cases are strong enough to stand on, yet are ultra-lightweight.

MIL-Spec Cases are available in a variety of heights, finishes and with a choice of closures, and three different panel mounting flanges. For the ultimate in watertight carrying cases, choose ZERO's Centurion® MIL-Spec series case.



FEATURES

- ▶ Watertight
- ▶ Gasketed Closures
- ▶ Separable Hinges to Remove Cover
- ▶ Closure features interlocking tongue and groove extrusion of 6063-T1 aluminum, permitting maximum sealing and alignment of two halves.

OPTIONS

- ▶ Hinged inner lids available as special order item.
- ▶ Panel Mounting Flange
- ▶ Panel Fabrication
- ▶ Mil-Spec Finishes
- ▶ Custom Engraving, Marking, Labeling

*Except to 0.50 PSI



OPTIONAL PANEL MOUNTING FLANGES

Case shown with optional feature.

FINISH OPTIONS

Note: Except latches, handle, grip, hinges, valve.

POWDER COAT PAINT RECOMMENDED

- BK**—Black 27038
- DB**—Dark Blue 25045
- DS**—Desert Sand 20372
- FG**—Forest Green 24079
- GR**—Gray 26307
- MB**—Medium Blue 25190
- NG**—NATO Green RAL6014
- OD**—Olive Drab 24097
- OR**—Orange 21400
- RD**—Red 21105
- WH**—White 27925
- YW**—Yellow 23538

FED-STD-595 for reference.

RHINOLINING™

- RB**—Black
- RG**—Gray

MIL-SPEC FINISHES

- A**—No Finish.
- B**—Chemical Film Per MIL-DTL-5541, Type I, Class 1A. Epoxy Primer per MIL-PRF-23377, Type 1, Class C2.
- C**—Same as B Plus Paint Light Gray Semi-Gloss Polyurethane Color #26307 of FED-STD-595.
- D**—Same as B Plus Paint Light Gray Semi-Gloss Polyurethane Color #16307 of FED-STD-595.
- E**—Wash Prime per DOD-P-15328 and Epoxy Primer per MIL-DTL-53022, Type II, Paint Polyurethane Yellow Gloss Color #13538 of FED-STD-595.
- F**—Same as B Plus Paint Strata Blue Gloss Polyurethane Color #15045 of FED-STD-595.
- G**—Same as B Plus Paint Green Semi-Gloss Polyurethane Color #24300 of FED-STD-595.

MIL-SPEC FINISHES cont.

- H**—Same as B Plus Paint Olive Drab Semi-Gloss Polyurethane Color #24084 of FED-STD-595.
- J**—Same as B Plus Paint Olive Drab Lusterless Polyurethane Color #34088 of FED-STD-595.
- K**—Same as B Plus Paint Aliphatic Polyurethane Camouflage Coating (CARC) per MIL-DTL-53039, Type II, Color #383 Green, #34094 of FED-STD-595.
- S**—Special Order—Please Specify.
- W**—Chemical Film Per MIL-DTL-5541, Type I, Class 1A. Epoxy Primer per MIL-DTL-53022, Type II, or Water-base Epoxy Primer per MIL-DTL-53030, Type I. Paint with White Polyurethane Coating per MIL-PRF-85285, Type II, Class H, Color #17925 of FED-STD-595 or Epoxy Coating Per MIL-PRF-22750.
- UA**—Chem Film per MIL-DTL-5541, Type I, Class 1A.

OTHER COLORS AND FINISHES AVAILABLE ON REQUEST

Commercial or military specification can be met in our completely equipped and staffed paint facility. In addition to supplying any color per FED-STD-595, PMS or RAL. ZERO has coded swatches to match any color.

PANEL FABRICATION

- Silk-Screening
- Engraving
- Custom Fabrication

CASE CUSTOMIZATION

- Stenciling
- Designation Printing
- Decals and Labels
- Silk-Screening

CENTURION® MIL-Spec

CASE DESCRIPTION AND HARDWARE

Basic Shell Dimensions.

CASE NUMBER	EXTERIOR		INTERIOR		D	E	F	G	H	R1	R2	R3	R4	MATERIAL THICKNESS
	A WIDTH	B LENGTH	C MIN	C MAX										
Z100P	9.00	12.00	2.50	3.36	3.50	1.75	1.34	2.81	0.09	1.00	1.00	6.00	1.00	0.040
Z101P	9.00	16.00	2.50	5.56	5.50	1.75	1.34	2.81	0.09	1.25	1.00	6.00	1.00	0.051
Z103P	13.00	18.00	2.50	5.91	6.40	2.00	1.75	5.12	0.12	1.25	1.00	6.25	1.00	0.040
Z105P	13.00	21.00	2.50	4.06	7.90	2.00	2.00	5.00	0.12	1.25	1.00	6.25	1.00	0.040
Z106P	17.00	21.00	2.78	4.81	7.46	2.68	2.25	7.13	0.12	1.25	1.25	6.50	1.25	0.051
Z109P	18.00	26.00	2.38	7.31	9.81	3.16	1.63	8.43	0.12	1.00	1.00	6.50	1.00	0.063
Z112P	18.00	24.00	2.78	4.81	8.87	2.93	2.25	7.64	0.12	1.25	1.25	6.50	1.25	0.051
Z114P	17.00	18.00	2.31	4.36	6.40	2.68	2.25	7.14	0.12	1.25	1.00	6.25	1.00	0.040
Z129P	20.00	29.00	2.78	5.02	11.31	2.94	2.25	9.62	0.12	1.25	1.25	6.50	1.25	0.051
Z132P	19.75	8.50	2.50	2.91	—	—	—	—	—	1.25	0.50	—	0.50	0.051

BASIC SHELL DIMENSIONS AND CASE SPECIFICATIONS

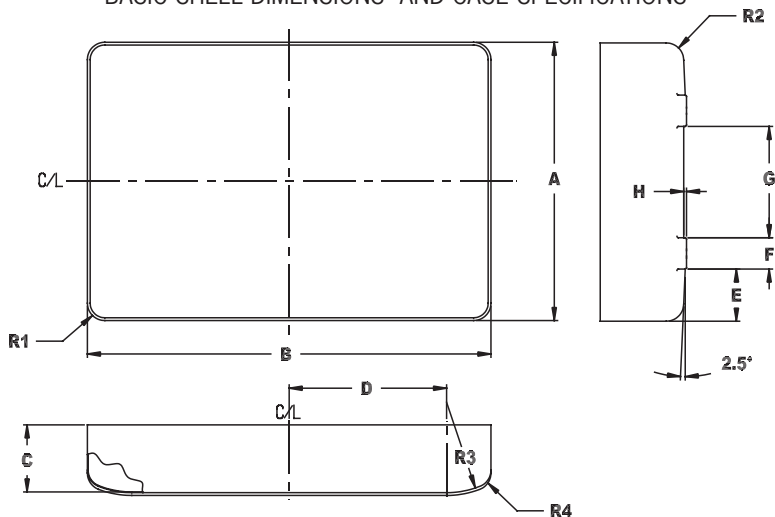

HANDLE

PART #ZSP3-304

- ▶ MATERIAL: 6061 -T6 Aluminum Alloy, Aluminum Plate, Steel Bail with 0.75 rubber grip
- ▶ WEIGHT: 0.183 lbs
- ▶ PERFORMANCE DATA: Design Load 50 lbs. Bail has 180° free swing

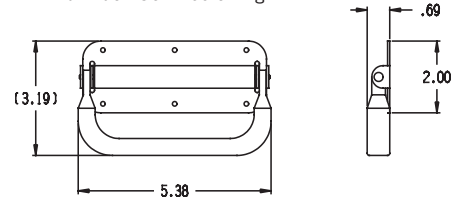

FEET

PART #ZP20118

- ▶ MATERIAL: 6061 -T6 Aluminum Alloy
- ▶ WEIGHT: 0.06 lbs

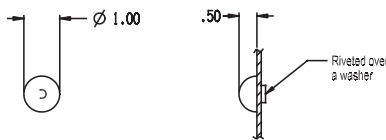

LATCH

PART #TC82Z20-01

- ▶ MATERIAL: Cold Rolled Steel
- ▶ WEIGHT: 0.108 lbs
- ▶ PERFORMANCE DATA: Positive Locking Bail Type

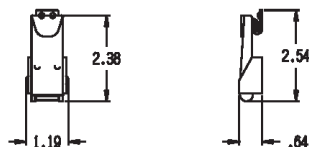

HINGE

PART #ZP20281-1 Long Pin
PART #ZP20281-2 Short Pin

- ▶ MATERIAL: Stainless Steel
- ▶ WEIGHT: 0.104 lbs
- ▶ PERFORMANCE DATA: Available in Separable Versions

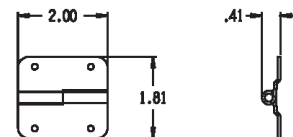

VALVES

PART #ZP20172 Manual Relief Valve

- ▶ MATERIAL: Aluminum Alloy
- ▶ WEIGHT: 0.02 lbs
- ▶ PERFORMANCE DATA: Complies with MS18014-1

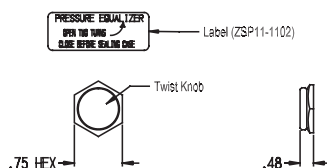

PART #ZSP6-037-1 Automatic Relief Valve

- ▶ MATERIAL: Aluminum Alloy, Stainless Steel Spring
- ▶ WEIGHT: 0.05 lbs
- ▶ PERFORMANCE DATA: Operating Media: Air or Nitrogen Temperature Range: -65° to +160° F Normal Ratings: Vacuum = 3.5 PSI Pressure = 2.5 PSI

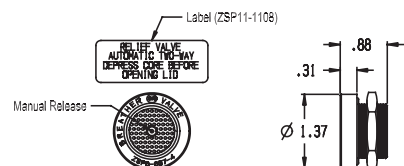

CENTURION[®] MIL-Spec

CLOSURE PANEL OPTIONS

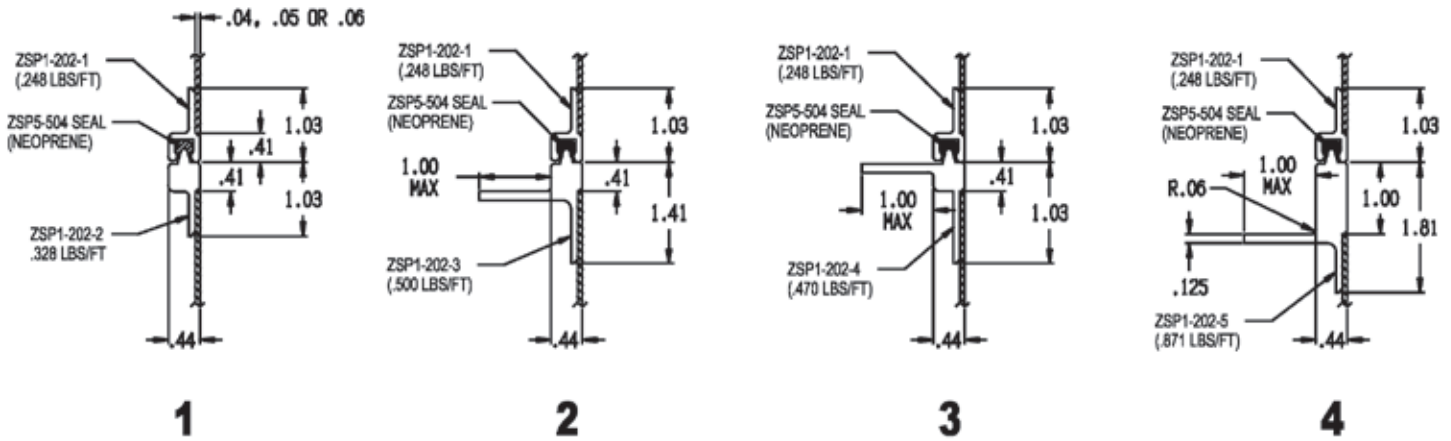

PANEL DIMENSIONS

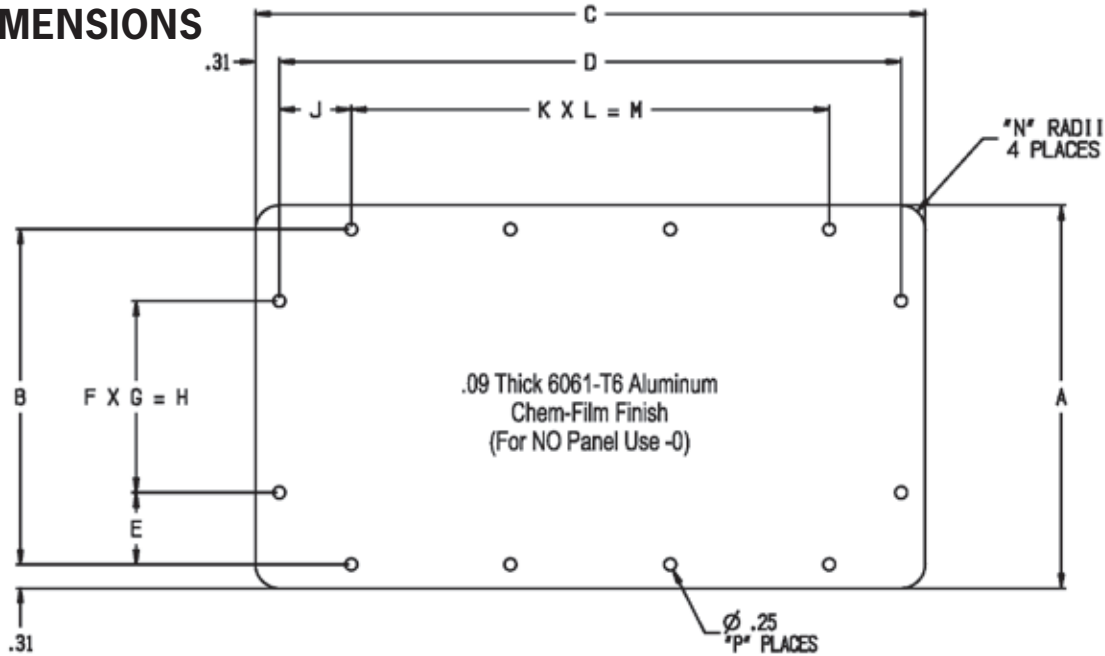

ZP21622 PANEL DIMENSIONS AND DASH PART NUMBERS

DASH NUMBER	CASE SIZE	A	B	C	D	E	F	G	H	J	K	L	M	N	P
-1	Z100P	7.92	7.300	10.92	10.300	1.650	1	4.000	4.000	1.650	2.00	3.500	7.000	0.50	10
-3	Z101P	7.90	7.280	14.90	14.280	1.640	1	4.000	4.000	1.140	3.00	4.000	12.000	0.75	12
-5	Z103P	11.92	11.300	16.92	16.300	1.650	2	4.000	8.000	1.150	4.00	3.500	14.000	0.75	16
-7	Z105P	11.92	11.300	19.92	19.300	1.650	2	4.000	8.000	1.650	4.00	4.000	16.000	0.75	16
-9	Z106P	15.90	15.280	19.90	19.280	1.640	3	4.000	12.000	1.640	4.00	4.000	16.000	0.75	18
-11	Z109P	16.88	16.250	24.88	24.250	1.125	4	3.500	14.000	1.625	6.00	3.500	21.000	0.44	24
-13	Z112P	16.90	16.280	22.90	22.280	1.140	4	3.500	14.000	1.140	5.00	4.000	20.000	0.75	22
-15	Z114P	15.92	15.300	16.92	16.300	1.650	3	4.000	12.000	1.150	4.00	3.500	14.000	0.75	18
-17	Z129P	18.90	18.280	27.90	27.280	1.140	4	4.000	16.000	1.640	6.00	4.000	24.000	0.75	24
-19	Z132P	7.40	6.780	18.65	18.030	1.340	1	4.000	4.000	1.015	4.00	4.000	16.000	0.75	14

Z100P

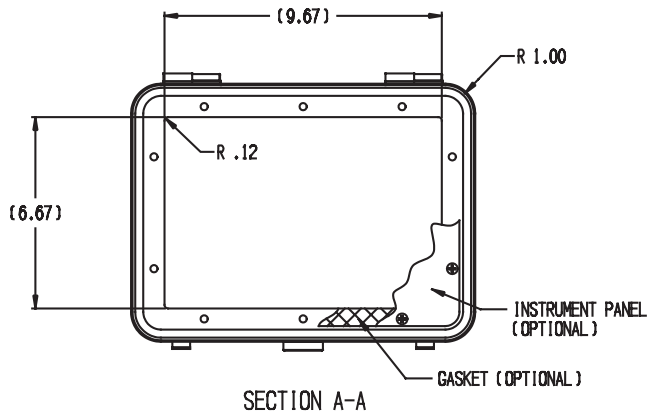

TO ORDER COMPLETE PART NUMBER BELOW:

CASE NUMBER	CLOSURE STYLE	VALVE TYPE	FINISH	OPTIONAL PANEL
100P	●	●	●	●

USE DASH NUMBER FROM PAGE 22

SEE PAGE 20 FOR OPTIONS

A FOR AUTOMATIC
M FOR MANUAL

SEE PAGE 22 FOR OPTIONS

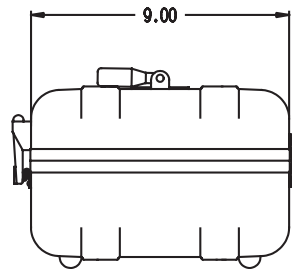
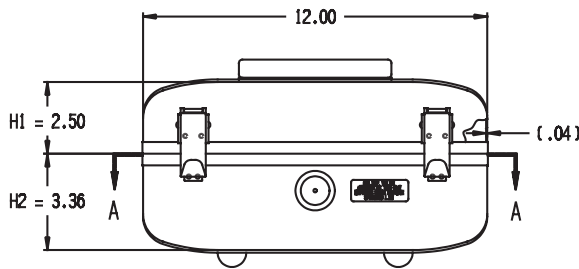

Z101P

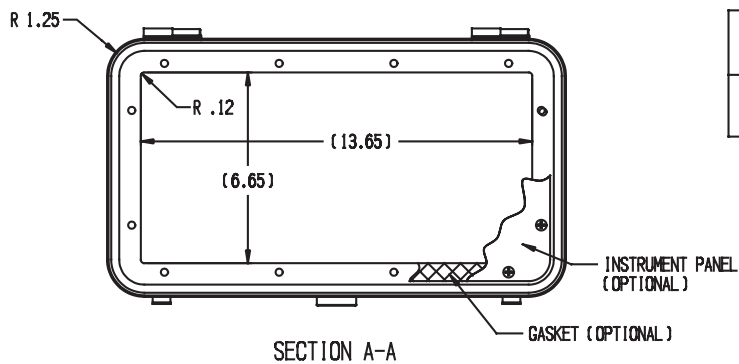

TO ORDER COMPLETE PART NUMBER BELOW:

CASE NUMBER	CLOSURE STYLE	VALVE TYPE	FINISH	OPTIONAL PANEL
101P	●	●	●	●

USE DASH NUMBER FROM PAGE 22

SEE PAGE 20 FOR OPTIONS

A FOR AUTOMATIC
M FOR MANUAL

SEE PAGE 22 FOR OPTIONS

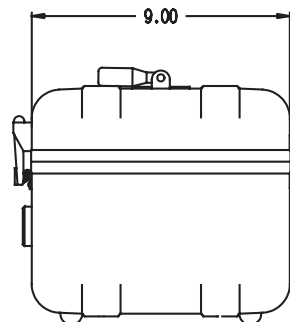
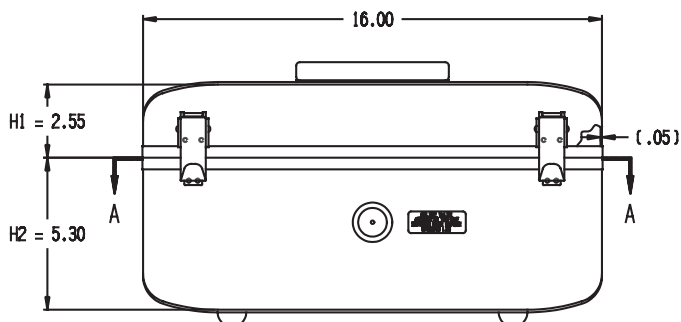

Z103P

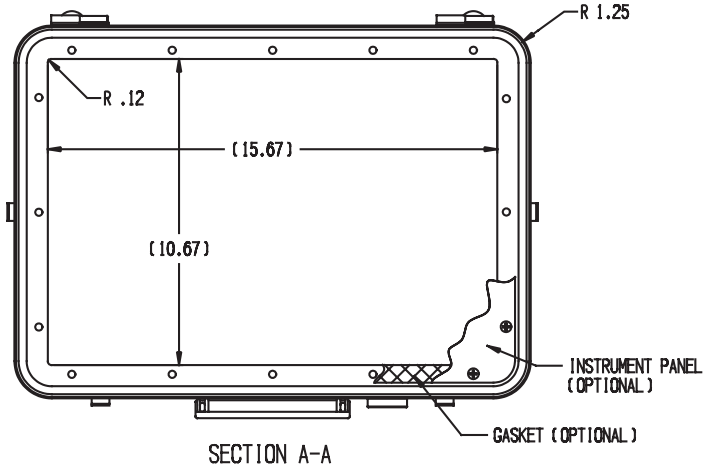

TO ORDER COMPLETE PART NUMBER BELOW:

CASE NUMBER	CLOSURE STYLE	VALVE TYPE	FINISH	OPTIONAL PANEL
Z103P	●	●	●	●

USE DASH NUMBER FROM PAGE 22
SEE PAGE 20 FOR OPTIONS

A FOR AUTOMATIC
M FOR MANUAL

SEE PAGE 22 FOR OPTIONS

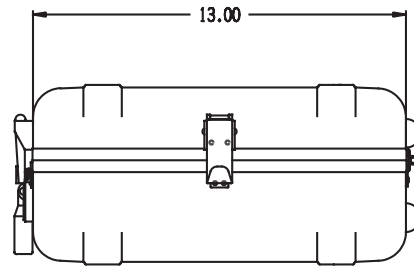
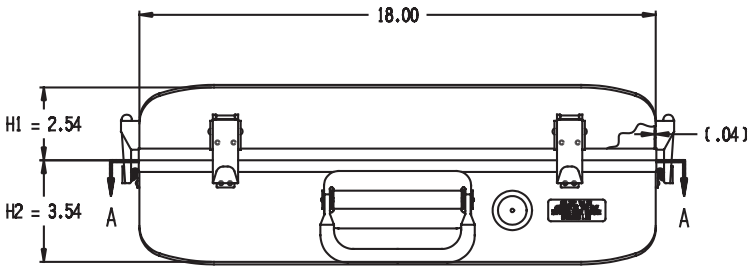

Z105P

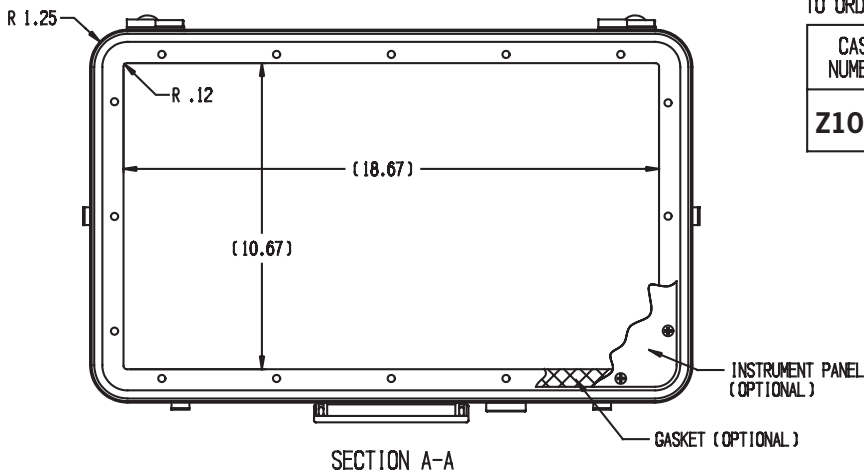

TO ORDER COMPLETE PART NUMBER BELOW:

CASE NUMBER	CLOSURE STYLE	VALVE TYPE	FINISH	OPTIONAL PANEL
Z105P	●	●	●	●

USE DASH NUMBER FROM PAGE 22

SEE PAGE 20 FOR OPTIONS

A FOR AUTOMATIC
M FOR MANUAL

SEE PAGE 22 FOR OPTIONS

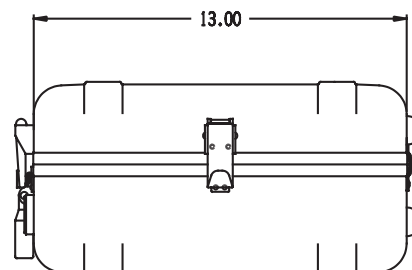
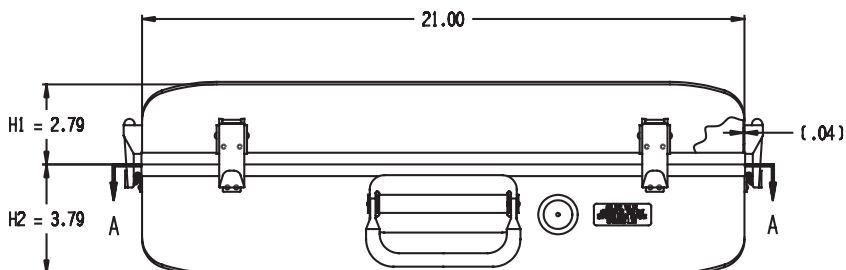

Z106P

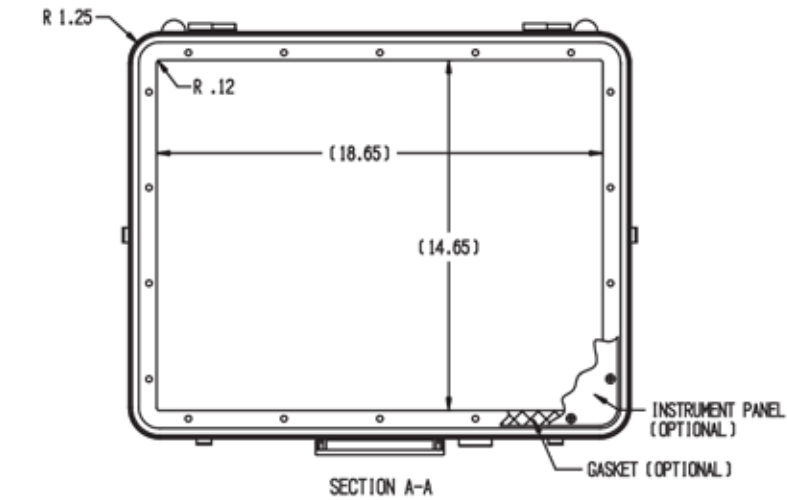

TO ORDER COMPLETE PART NUMBER BELOW:

CASE NUMBER	CLOSURE STYLE	VALVE TYPE	FINISH	OPTIONAL PANEL
Z106P	●	●	●	●

USE DASH NUMBER FROM PAGE 22
SEE PAGE 20 FOR OPTIONS

A FOR AUTOMATIC
M FOR MANUAL

SEE PAGE 22 FOR OPTIONS

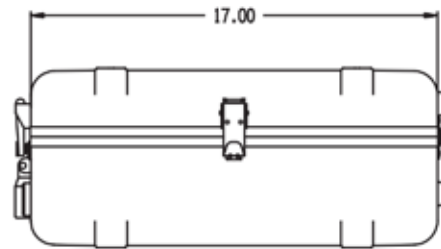
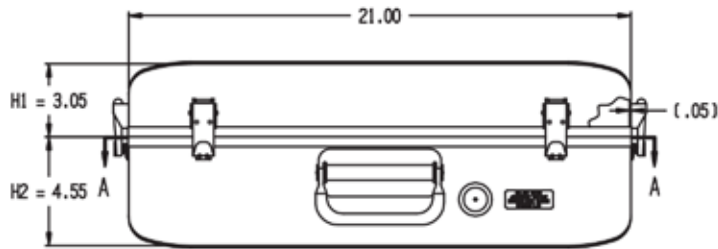

Z109P

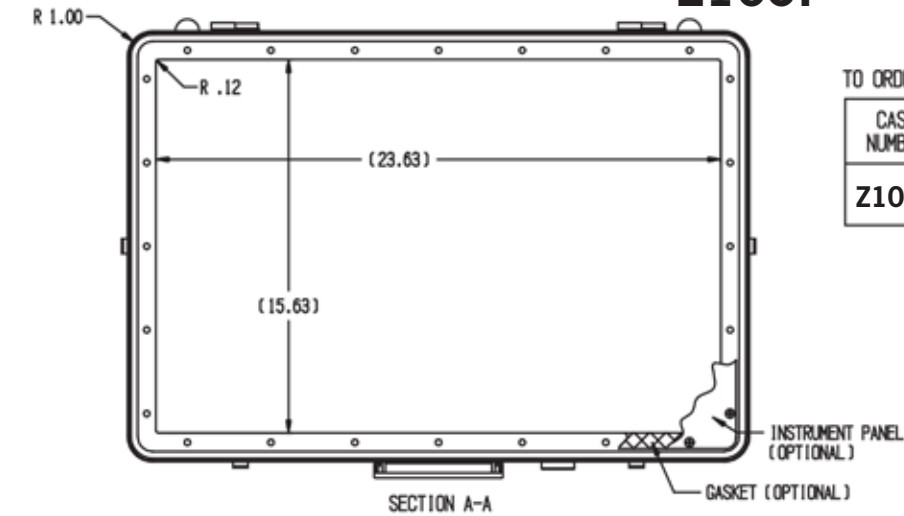

TO ORDER COMPLETE PART NUMBER BELOW:

CASE NUMBER	CLOSURE STYLE	VALVE TYPE	FINISH	OPTIONAL PANEL
Z109P	●	●	●	●

USE DASH NUMBER FROM PAGE 22

SEE PAGE 20 FOR OPTIONS

A FOR AUTOMATIC
M FOR MANUAL

SEE PAGE 22 FOR OPTIONS

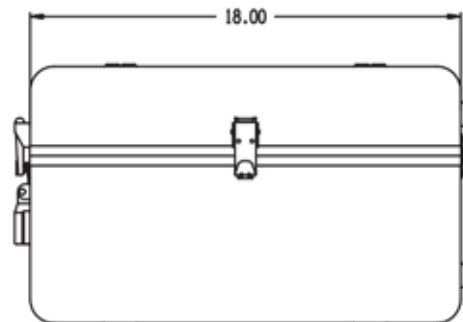
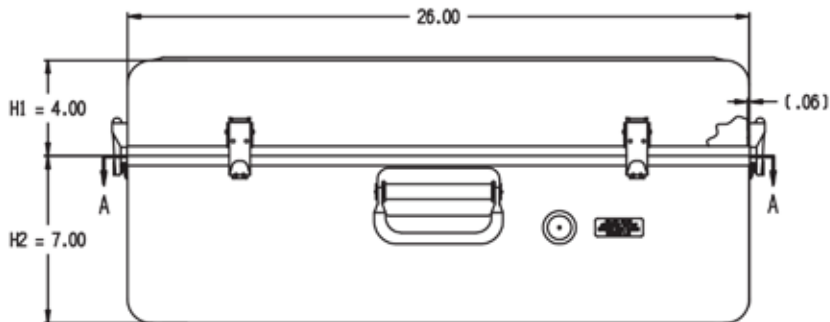

Z112P

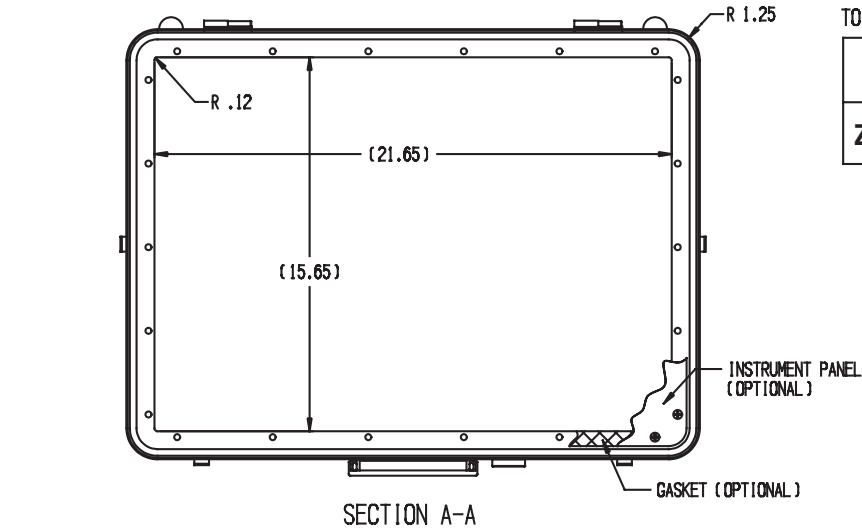

TO ORDER COMPLETE PART NUMBER BELOW:

CASE NUMBER	CLOSURE STYLE	VALVE TYPE	FINISH	OPTIONAL PANEL
Z112P	●	●	●	●

USE DASH NUMBER FROM PAGE 22

SEE PAGE 20 FOR OPTIONS

A FOR AUTOMATIC
M FOR MANUAL

SEE PAGE 22 FOR OPTIONS

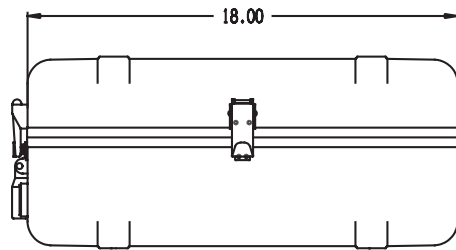
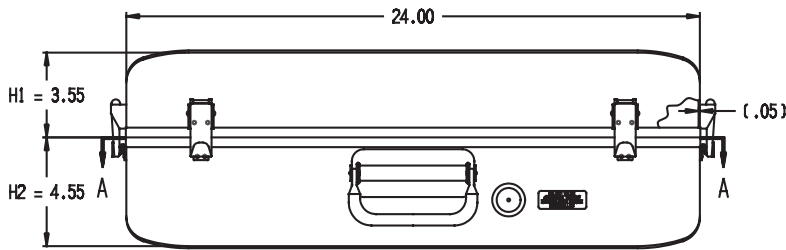

Z114P

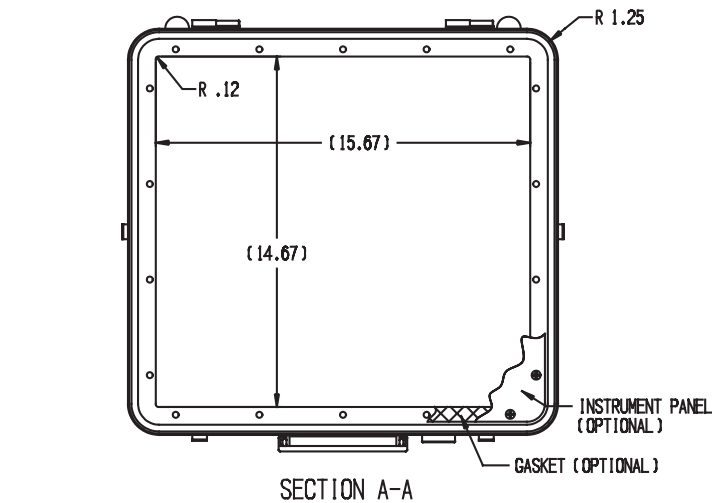

TO ORDER COMPLETE PART NUMBER BELOW:

CASE NUMBER	CLOSURE STYLE	VALVE TYPE	FINISH	OPTIONAL PANEL
Z114P	●	●	●	●

USE DASH NUMBER FROM PAGE 22

SEE PAGE 20 FOR OPTIONS

A FOR AUTOMATIC
M FOR MANUAL

SEE PAGE 22 FOR OPTIONS

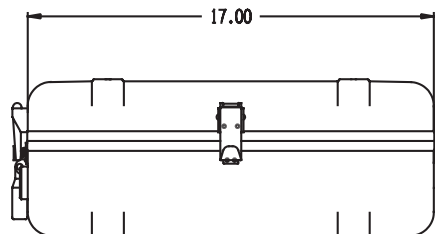
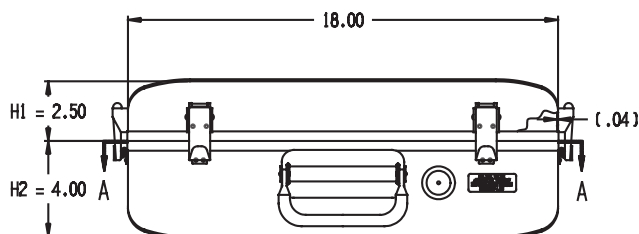

Z129P

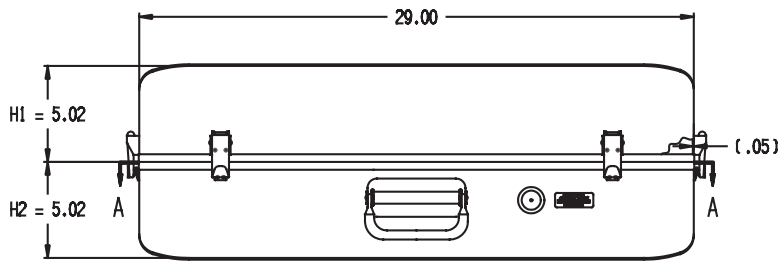
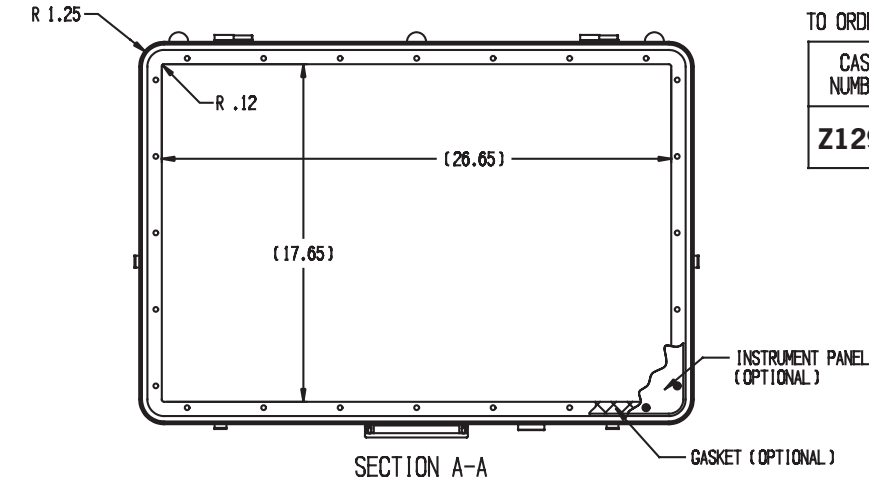

TO ORDER COMPLETE PART NUMBER BELOW:

CASE NUMBER	CLOSURE STYLE	VALVE TYPE	FINISH	OPTIONAL PANEL
Z129P	●	●	●	●

USE DASH NUMBER FROM PAGE 22

SEE PAGE 20 FOR OPTIONS

A FOR AUTOMATIC
M FOR MANUAL

SEE PAGE 22 FOR OPTIONS

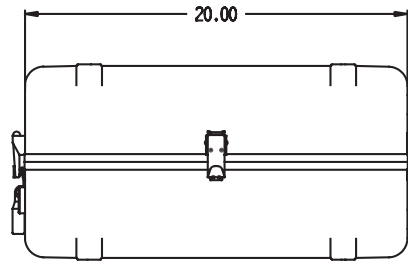

Z132P

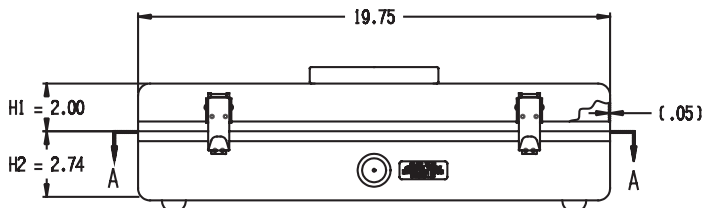
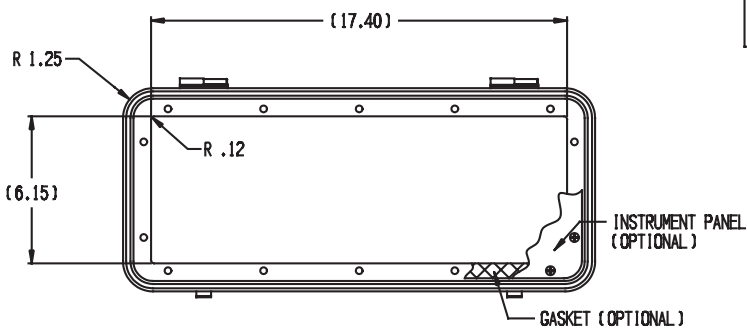

TO ORDER COMPLETE PART NUMBER BELOW:

CASE NUMBER	CLOSURE STYLE	VALVE TYPE	FINISH	OPTIONAL PANEL
Z132P	●	●	●	●

USE DASH NUMBER FROM PAGE 22

SEE PAGE 20 FOR OPTIONS

A FOR AUTOMATIC
M FOR MANUAL

SEE PAGE 22 FOR OPTIONS

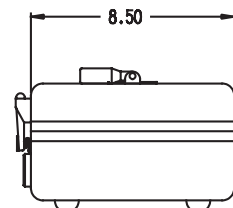

NOTE: CASE SHELLS ARE NOT BEADED.

VALULINE™

ALUMINUM CASES

VALULINE

▶ THE VALULINE™ SERIES PROVIDES A VARIETY OF FEATURES AND OPTIONS IN SELECTING A CASE

- ▶ Constructed of deep drawn aluminum shells, the case shells are seamless.
- ▶ Three closure options.
- ▶ Variations of internal panel mounting, give added versatility in the packaging of electronic, electro-mechanical, or instrumentation equipment.
- ▶ Custom sizes—You may design a case from the standard sizes of deep drawn enclosures in the Deep Drawn Catalog.
- ▶ All listed sizes can be utilized without a tooling charge.



VALULINE FEATURES AND SPECIFICATIONS

- ▶ Material: Aluminum Alloy.
- ▶ Latches: Zamak #7—nickel plated.
- ▶ Hinges: Riveted-nickel plated steel. Separable on all styles.
- ▶ Handle: Black molded plastic with nickel plated hardware.
- ▶ Feet: ZIC & ZC Series: Integral dimpled; ZIP Series: Four, black rubber.
- ▶ Gasket: Black extruded synthetic rubber—ZC and ZIP Series.
- ▶ Panels: Aluminum with chemical film finish. Material Thickness—0.090".
- ▶ Tolerances: ± 0.06"

See page 32-37 for dimensions and details.

▶ SELECT FROM 13 TEXTURED POWDER COAT PAINT FINISHES FOR INTERIOR & EXTERIOR, LESS HARDWARE

- 00 Olive Drab Powder Coat, Color No. 24097
- BK Black Powder Coat, Color No. 27038
- DB Dark Blue Powder Coat, Color No. 25045
- DS Desert Sand Powder Coat, Color No. 20372
- FG Forest Green Powder Coat, Color No. 24079
- GR Gray Powder Coat, Color No. 26307
- LG Light Gray Powder Coat, Color No. 26622
- MB Medium Blue Powder Coat, Color No. 25190
- NG Nato Green Powder Coat, Color No. RAL6014
- OR Orange Powder Coat, Color No. 21400
- RD Red Powder Coat, Color No. 21105
- WH White Powder Coat, Color No. 27925
- YW Yellow Powder Coat, Color No. 23538

▶ CUSTOM COLORS ARE AVAILABLE—FED-STD-595, RAL, PANTONE MATCHING SYSTEM OR SPECIAL.

FED-STD-595 numbers for reference.

Case dimensions are always shown in the following order:

- ▶ WIDTH—the narrowest measurement, looking down on the case.
- ▶ LENGTH—the longest measurement, looking down on the case.
- ▶ HEIGHT—measured from base to top. The “upper” shell is designated H¹. The “lower” shell is designated H².

RADIUS

R¹ = The radius at the bottom of drawn shells.

R² = The radius at the sides of drawn shells.

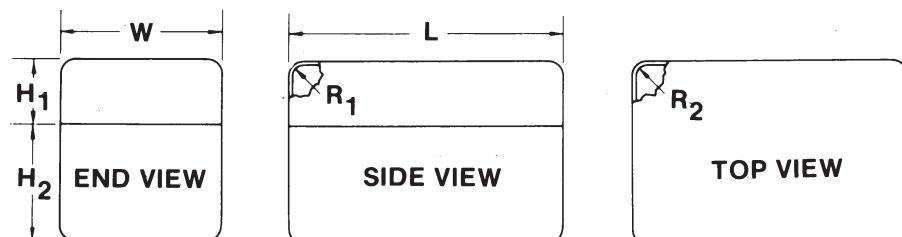

VALULINE™

ZC 7000 SERIES

- ▶ Most economical of the VALULINE cases.
- ▶ Available in 11 off-the-shelf sizes.
- ▶ ZC 7000 Series include separable hinges.
- ▶ All cases feature fully gasketed, bonded closures which fit over the edge of the lower shell.

ZC 7000 SERIES CASE	EXTERIOR				INTERIOR		ALLOY	T	LATCHES		WEIGHT LBS
	W	L	H ¹	H ²	R ¹	R ²			FRONT	SIDE	
ZC7010	4.00	7.00	1.25	2.91	0.31	0.31	1100-0	0.06	2	-	1.30
ZC7020	4.00	8.75	1.25	2.91	0.19	0.25	1100-0	0.06	2	-	1.60
ZC7030	5.00	7.00	1.25	3.66	0.31	0.31	1100-0	0.06	2	-	1.70
ZC7040	5.50	8.00	1.25	3.66	0.25	0.25	1100-0	0.06	2	-	1.80
ZC7050	5.69	10.00	1.25	4.66	0.25	0.25	1100-0	0.06	2	-	2.30
ZC7060	6.00	9.00	1.25	4.66	0.31	0.31	1100-0	0.06	2	-	2.20
ZC7070	6.00	14.50	1.38	4.53	0.44	0.50	1100-0	0.06	2	-	2.90
ZC7080	7.00	11.00	1.50	5.41	0.50	0.31	6061-0	0.06	2	-	2.90
ZC7090	8.00	14.00	1.88	6.03	0.88	0.88	6061-0	0.06	2	-	3.80
ZC7100	9.00	9.00	1.50	6.41	0.50	0.50	6061-0	0.06	2	-	3.20
ZC7110	9.18	13.25	1.63	7.28	0.59	0.59	6061-0	0.06	2	1	4.60

Measurements shown in inches. T=thickness. See page 32 for Valuline case specifications.

▶ ORDER STANDARD SIZES

ORDER BY CASE NUMBER

ZC _____

Color _____

▶ ORDER CUSTOM SIZES

Order by Series Number and specify detail information. See ZERO's Deep Drawn Products Catalog for additional sizes.

Secondary Operations Available.

PLEASE SPECIFY

Width _____

Length _____

Color _____ PAGE 32



CONTACT US

NEED A QUOTE? Have questions?

Want to learn more? Contact ZERO.

quotes@zerocases.com | www.zerocases.com

Fax 801.415.1771 | Direct 801.299.5978



800.500.9376

VALULINE™

ZIP 800 SERIES

ALUMINUM CARRYING CASES

- ▶ Most versatile series of the VALULINE cases.
- ▶ Fully gasketed closure of extruded aluminum, spot-welded to the interior case shell.
- ▶ Permits installation of optional panel support brackets.
- ▶ Permits full size primed panel (order separately).
- ▶ O-ring gasket provides additional environmental protection.



SEE PAGE 32 FOR VALULINE CASE SPECIFICATIONS.

CASE ① NUMBER	W	L	H ¹	H ²	T	ALLOY	R ¹	R ²	FRONT	LATCHES		PANEL ② NUMBER	STANDARD MOUNTING BRACKETS	WT LBS
										SIDE	HINGES			
ZIP805	6.00	9.00	2.50	5.00	.06	1100-0	.31	.31	2	-	2	ZP9178-05	4	2.9
ZIP810	7.00	11.00	2.50	7.00	.06	6061-0	.50	.31	2	-	2	ZP9178-10	4	3.9
ZIP820	8.00	14.00	2.50	7.00	.06	6061-0	.88	.88	2	-	2	ZP9178-20	6	4.8
ZIP830	8.75	12.00	2.50	8.00	.06	6061-0	.50	.75	2	-	2	ZP9178-30	6	4.8
ZIP840	9.19	13.25	2.50	9.00	.06	6061-0	.59	.59	2	-	2	ZP9178-40	6	5.6
ZIP850	10.00	16.00	2.50	9.00	.09	6061-0	1.00	1.00	2	1	3	ZP9178-50	8	8.8

Note: W, L and H are exterior dimensions, R¹ and R², are interior dimensions. T= Thickness. Measurements shown in inches.

▶ ORDER STANDARD SIZES

ORDER BY PART NUMBER FOR EACH ITEM

CASE, PANEL AND/OR BRACKETS, AND COLOR

EXAMPLE:

ORDER BY CASE NUMBER PANEL REQUIRED
 ZIP _____ ① ZP9178 - _____ ②

See Table Above

See Table Above

BRACKETS REQUIRED
 ZSP9-014-3 _____

Specify Quantity

COLOR REQUIRED

See Page 32

▶ ORDER CUSTOM SIZES

Order By Series Number and Specify Detail Information. See ZERO's Deep Drawn Products Catalog for additional sizes.

Secondary Operations Available.

PLEASE SPECIFY

Width _____

Length _____

Cover Height H¹ _____

Case Height H² _____

Color _____ PAGE 32



ZIP 800 SERIES PANEL DIMENSIONS

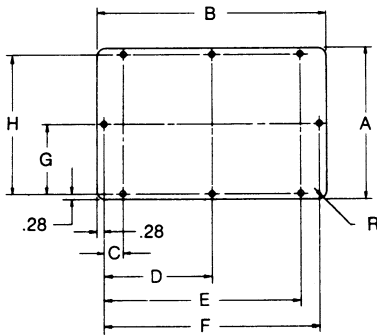

PANEL NUMBER	A	B	C	D	E	F	G	H	R	# OF HOLES
ZP9178-05	5.37	8.37	1.50	-	6.31	-	-	4.81	0.19	4
ZP9178-10	6.37	10.37	2.00	-	7.81	-	-	5.81	0.19	4
ZP9178-20	7.37	13.37	2.88	-	9.94	12.81	3.41	6.81	0.63	6
ZP9178-30	8.12	11.37	2.00	-	8.81	10.81	3.78	7.56	0.50	6
ZP9178-40	8.56	12.62	2.50	-	9.56	12.06	4.00	8.00	0.44	6
ZP9178-50	9.31	15.31	2.50	7.37	12.25	14.75	4.38	8.75	0.75	8

Measurements shown in inches.
 Material: 6061-T6 Aluminum Alloy. Thickness = 0.090"
 Finish: Epoxy primer per MIL-PRF-23377, Type I, CLASS C2.

▶ ADJUSTABLE PANEL SUPPORT BRACKET

PART #ZSP9-014-3 Optional Accessory
 The adjustable panel support bracket shown is an accessory. If required, specify quantity needed for interface with equipment panel (See ordering information).

Installation instructions shown at right.

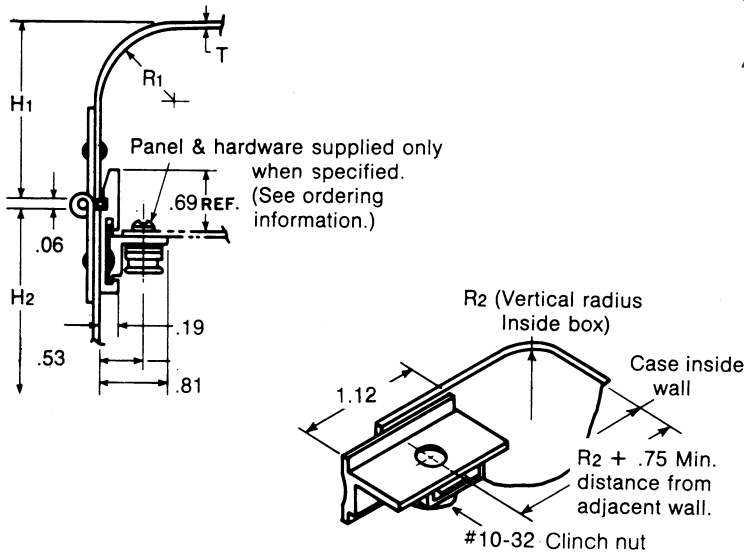

INSTRUCTIONS FOR PERMANENT INSTALLATION OF PANEL SUPPORT BRACKET

1. Apply room temperature cure epoxy to contact surface of support bracket and insert bracket into extrusion slot as shown.
2. Rotate downward, as shown, until support bracket is seated.
3. Slide bracket laterally as required to align bracket with panel hole location.
4. Allow epoxy to cure prior to further handling. (Note: Epoxy can be obtained locally at most hardware or industrial supply houses.)

BRACKET INSTALLATION DIAGRAM

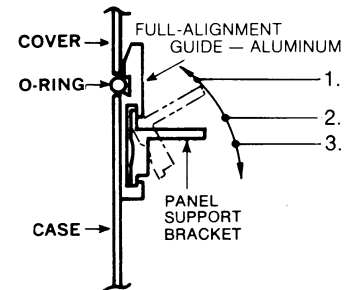

NEED A QUOTE? Have questions?

Want to learn more? Contact ZERO.

Call Toll Free 800.959.5050

quotes@zerocases.com | www.zerocases.com

Fax 801.415.1771 | Direct 801.299.5978



CENTURION® VALULINE

ZIC 600 SERIES ALUMINUM CARRYING CASES

- ▶ Spot-welded, pre-drilled panel flange.
- ▶ Threaded inserts installed to accept a full-sized panel.

- ▶ **Includes** a chemical film finished panel with basic case.
- ▶ **Finish:** 13 Powder Coat Paint Finishes or Custom. See Page 32.

CASE ① NUMBER	W	L	H ¹	H ²	T	ALLOY	R ¹	R ²	C	S	P	SIZE PANEL	WT LBS
ZIC608	7.00	8.00	2.50	6.00	0.06	1100-0	0.31	0.31	0.25	5.38	6.38	6.50 x 7.50	3.3
ZIC609	9.00	9.00	2.50	8.00	0.06	6061-0	0.50	0.50	0.25	7.38	7.38	8.50 x 8.50	4.7
ZIC610	6.69	10.69	2.50	6.00	.09	6061-0	0.50	0.50	0.22	5.00	9.00	6.19 x 10.19	4.8
ZIC611	7.00	11.00	2.50	6.00	0.06	6061-0	0.50	0.31	0.34	5.38	9.38	6.31 x 10.31	4.3
ZIC612	8.38	11.50	2.50	7.00	0.06	6061-0	0.50	0.56	0.25	6.75	9.87	7.88 x 11.00	4.9
ZIC613	9.19	13.25	2.50	9.00	0.09	6061-0	0.56	0.56	0.28	7.50	11.56	8.69 x 12.63	8.2
ZIC616	10.00	16.00	2.50	9.00	0.09	6061-0	1.00	1.00	0.28	8.31	14.31	9.50 x 15.50	9.8

Note: W, L and H are exterior dimensions, R¹, R², P and S are interior dimensions. T = Thickness. Measurements shown in inches. See page 32 for Valuline case specifications.

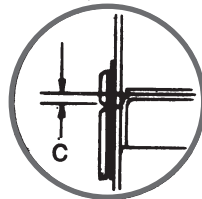

LATCH ASSEMBLY
REFERENCE

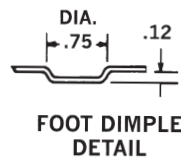

FOOT DIMPLE
DETAIL

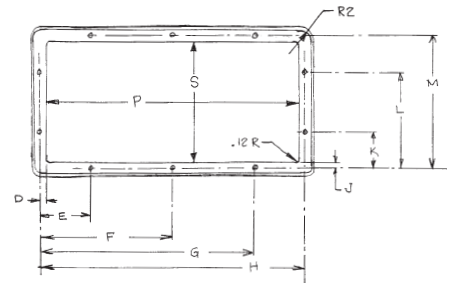

HOLE PATTERN DIMENSIONS

CASE	D	E	F	G	H	J	K	L	M
ZIC608	0.28	2.00	-	4.94	6.94	0.28	1.47	4.47	5.94
ZIC609	0.28	2.00	-	5.94	7.94	0.28	2.00	5.94	7.94
ZIC610	0.29	2.36	-	7.23	9.59	0.29	1.36	4.23	5.59
ZIC611	0.23	3.00	-	6.84	9.84	0.23	1.75	4.09	5.84
ZIC612	0.28	3.00	-	7.44	10.44	0.28	2.00	5.31	7.31
ZIC613	0.26	3.05	6.05	9.05	12.09	0.26	2.00	6.03	8.03
ZIC616	0.29	3.45	7.45	11.45	14.91	0.29	2.50	6.41	8.91

▶ ORDER STANDARD SIZES

ORDER BY CASE NUMBER

ZIC _____ ① See Table Above

Color _____ See Page 32

▶ ORDER CUSTOM SIZES

Order by series number and specify detail information. See ZERO's Deep Drawn Products Catalog for additional sizes.

Secondary Operations Available.

PLEASE SPECIFY

Width _____

Length _____

Cover Height H¹ _____

Case Height H² _____

Color _____

PAGE 32

Call Toll Free 800.959.5050

Direct 801.299.5978 Fax 801.415.1771

Email Sales@ZEROcases.com Web www.ZEROcases.com

CENTURION® VALULINE

ZIC 400 SERIES INSTRUMENT CASES

OFF-SHELF AVAILABILITY WITH NO TOOLING CHARGE

These distinctively designed deep drawn aluminum instrument cases give small instruments a sales-appealing custom appearance at off-the-shelf prices.

- ▶ Seamless deep drawn body provides protection even under rugged conditions.
- ▶ Aluminum front panel, recessed for protection of dials, meters, knobs, etc., is attached with four slotted screws for quick access.

SPECIFICATIONS

- ▶ Material: ZIC 407 to 409: 1100-0, 0.063" Aluminum
ZIC 411: 6061-0, 0.063" Aluminum
- ▶ Handle: Cast Aluminum, Brushed Finish
- ▶ Feet: Rubber
- ▶ Finish: Select from 13 Powder Coat Paint Colors, or Custom. See Page 32.



CASE NUMBERS AND DIMENSIONS

CASE	Exterior Width	Exterior Length	Depth	Interior Radius 1	Interior Radius 2	Approx. Weight
ZIC407	4.00	7.00	5.00	0.31	0.31	1.3
ZIC408	4.50	7.75	7.00	0.25	0.25	1.8
ZIC409	6.00	9.00	5.00	0.31	0.31	2.1
ZIC411	7.00	11.00	7.00	0.50	0.31	2.9

Note: measurements shown in inches. Weight shown in lbs. See page 32 for Valuline case specifications.

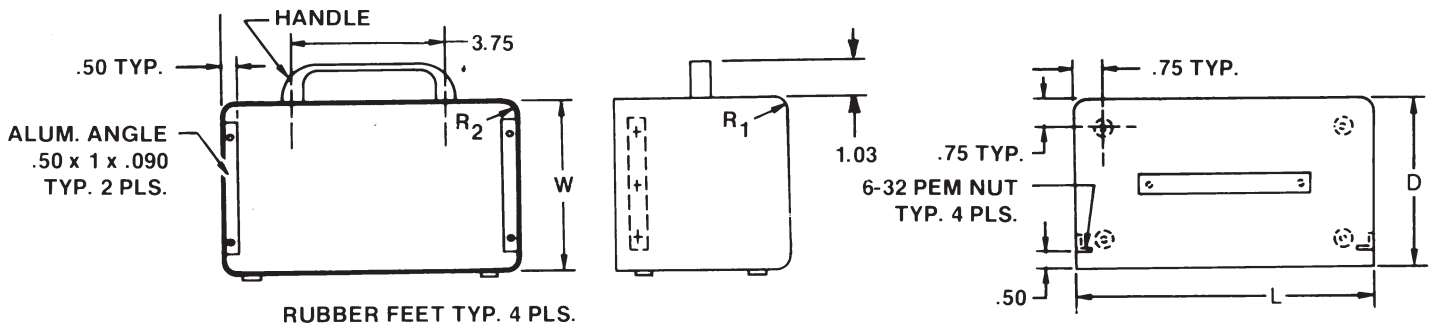

▶ ORDER STANDARD SIZES

ORDER BY CASE NUMBER

ZIC _____ See Table Above

Color _____ See Page 32

▶ ORDER CUSTOM SIZES

Order by series number and specify detail information. See ZERO's Deep Drawn Products Catalog for additional sizes.

Secondary Operations Available.

PLEASE SPECIFY

Width _____

Length _____

Depth _____

Color _____

PAGE 32

NEED A QUOTE? Have questions?

Want to learn more? Contact ZERO.

quotes@zerocases.com | www.zerocases.com

Fax 801.415.1771 | Direct 801.299.5978

Toll Free 800.959.5050

CENTURION® VALULINE

MODIFIED INSTRUMENT CASE HARDWARE

Standard Hardware Options

▶ HANDLES

PART #ZP20085

Used on ZIC 600, ZIP 800, ZC 7000 Series.

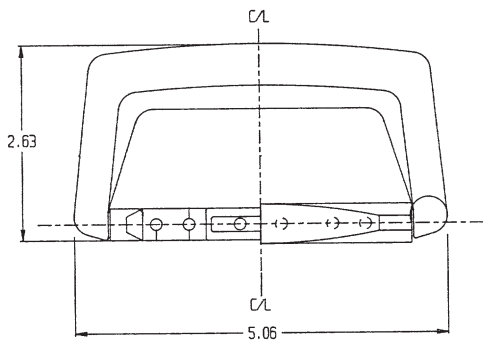

PART #5207-28A

Used on ZIC 400 Series Instrument Cases

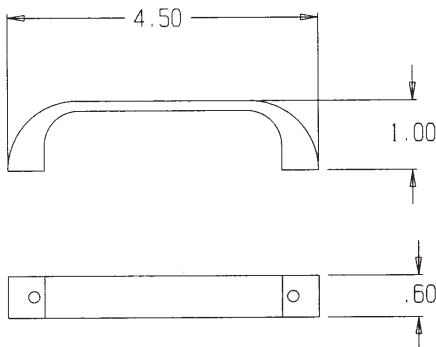

▶ HINGES

PART #ZSP4-4002-1 Separable (long pin)

PART #ZSP4-4002-2 Separable (short pin)

PART #ZP20282-3 Non-Separable

MATERIAL: Varies

WEIGHT: Varies

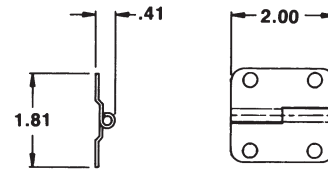

▶ FEET

PART #ZSP7-718

Used on ZIP 400, ZIP 800 Series

MATERIAL: Rubber

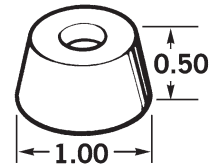

PART #BB4085

Used on ZIP 400 Series

MATERIAL: Rubber

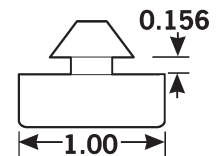

▶ LATCHES

PART #ZSP2-220-1

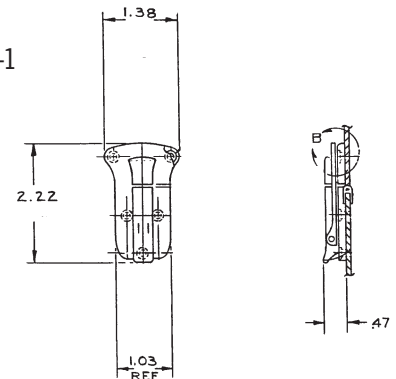

▶ ORDERING INFORMATION

- Select Case/Model No.
- Specify Inner Lid *As Required*
- Support Brackets Quantity
As Required
- Hardware
- Color *See Page 32*

Toll Free 800.959.5050

Direct 801.299.5978 Fax 801.415.1771

Email Sales@ZEROCases.com | Web www.ZEROCases.com



GLOSSARY OF TERMS

Alloy: An aluminum alloy is a metal that is a mixture of aluminum and one or more other elements.

1100: 99% pure aluminum.

3003: Aluminum/manganese alloy.

6061: Aluminum/manganese/silicon alloy.

Anodizing: Electrochemically converting the surface of aluminum from metallic aluminum to aluminum oxide (alumina) by making aluminum the anode in a plating-type electrochemical cell. It is used not only for added protection, but also in conjunction with dyeing and sealing to create decorative effects.

Artificial Aging: Speeding up the natural aging cycle by heating the metal for a short time.

CF: Flush fitting cover.

CI: Interior fitting cover.

COG: Exterior fitting cover with gasket clearance.

COL: Exterior fitting cover with loose fit.

COT: Exterior fitting cover with tight fit.

Cold Working: Applying a mechanical force (such as deep drawing) to metal at room temperature at such a rate that strain-hardening occurs.

Deep Drawing: Using a ram to force an aluminum sheet into a draw die to produce a shell. See also draw die. Deep drawing is also used to produce many cup-shaped products in other industries.

Die: See draw die.

Draw Die: Tooling used in the deep drawing process to produce shells.

EMI Gasket: A gasket used in closures and on panel flanges to keep EMI radiation from entering or escaping from an enclosure.

EMI Shielding: Shielding against radiated or conducted EMI/RFI.

Flange: A rim into which a panel can be mounted.

Hardening: Increasing the hardness of metal by suitable treatment such as by strain or heat. Associated with processes such as age hardening, strain or work hardening, precipitation hardening, or quench hardening.

Heat Treat: Temper produced by heating.

Heat-Treatable Alloy: An aluminum alloy that can be hardened by heat treatment. Generally includes those alloys in 2XXX, 6XXX, and 7XXX series.

Height: The depth of a shell.

Mu-metal: A metal with high nickel content (78% nickel, iron, plus other additions) providing high magnetic permeability. Mu-metal shells are used as enclosures or covers for shielding/magnetically isolating critical parts from magnetic interference. Mu-metal 'absorbs' magnetic lines in the vicinity rather than allowing them to pass through critical components.

Nutplate: A nut capable of receiving a screw for mounting a panel, etc.

O.D.: Outside diameter measured at tangency between bottom radius (R^1) and side.

Points of Tangency: The points at which the straight portions of the shell walls intersect the beginning of the radius corners.

Precipitation Hardening: A metal-treating process that increases the strength of aluminum by precipitation alloying material into the structure of aluminum. Natural aging is involved if the process occurs at room temperature, while artificial aging involves the application of heat.

Quenching: The quick chilling of aluminum to retain, at room temperature, the metallurgical structure produced by heat treatment at an elevated temperature.

R^1 : The radius at the bottom of drawn shells.

R^2 : The radius at the sides of drawn shells.

Reflectivity: The ability of a surface to mirror or reflect radiant energy. The reflectance of aluminum is exceptionally high.

RFI: Radio frequency interference.

Seamless Construction: An exceptional attribute of deep drawn shells. Deep drawn shells have no seam.

Secondary Aluminum: Metal recovered aluminum scrap, segregated by alloy, and remelted to produce purified metal. One of its more important uses is in the foundry industry. A great advantage of aluminum is that it can be recycled indefinitely, as a secondary product. This not only preserves aluminum as a natural resource, but it also saves energy, since secondary aluminum is less costly to produce.

Solution Heat Treating: A strengthening thermal treatment in which certain aluminum alloys are heated to a relatively high temperature and then held (soaked) for varying times. A rapid quench or natural aging follows the heating period.

Strain Harden: Tempering through strain. Same as work harden.

Strength-to-Weight Ratio: The ratio of tensile strength to the weight of a material.

T: Material thickness.

Tangency: See points of tangency.

Temper Code: A letter-number code which designates heat treatment and cold work processes to create a temper.

Tensile Strength: The maximum pulling load that a material can sustain without failure.

Work Hardening: Hardening which occurs as the result of deforming metal crystals. Same as strain hardening. Results from deep drawing and other cold forming processes, including bending.

ZERO Method: The technologies and craft of ZERO Manufacturing, Inc. deep drawn products.

Products



DEEP DRAW COMPONENTS

- Precision Miniatures
- Stock Enclosures
- Value Added Enclosures
- In-Stock Deep Draw



CARRYING CASES

- Style-Lite™
- Valuline™
- Centurion® Elite™
- Centurion® MIL-Spec
- Centurion® On Demand



19" RACK MOUNTS

- Warrior™
- Scout™
- Val-An 700™
- Val-An 900™
- ZERAK™



TRANSIT AND STORAGE CONTAINERS

- Transittainer™
- Val-An™
- Pre-Engineered Cases
- Modular Containers

Services

DESIGN

- Product Design
- Product Engineering
- Custom Foam
- Prototyping

FABRICATION

- Production/Manufacturing
- Assembly
- Drop Testing
- Environmental Testing

- Heat Treating
- Perforating
- Sheet Metal Fabrication
- Tool and Die Creation
- Welding

FINISHING

- Anodizing
- Chemical Etching
- Painting
- Powder Coating
- Silkscreening

Industries

- Military & Defense
- Aerospace

- Broadcast/Telecom
- Medical

- Electronics
- Industrial

- Homeland Defense

ZERO Knows...

PLASTIC & METAL

ZERO is the premier manufacturer of both metal and plastic protective enclosures.

DEEP DRAWN

ZERO perfected the deep draw process and has the largest range of tooling in the world. Large or small, we can handle virtually any deep draw requirement.

CUSTOM SOLUTIONS

ZERO's capabilities range from very small custom enclosures to very large and complex fabricated assemblies.

SPEED

Manufacturing accelerates production lead times, so your product reaches you faster! Ask about our Quick-Ship, In-Stock and 'On-Demand' Programs.

SUCCESS

ZERO's solutions are time-tested and field proven. With over 100 years engineering experience and 50 years, ZERO cases have been the benchmark for durability and longevity.

ZERO MANUFACTURING, INC.

500 West 200 North | North Salt Lake, Utah 84054 USA
Toll Free US 800.500.9376 (ZERO)
Direct 801.298.5900 | Fax 801.299.7389
Email sales@zerocases.com | Web www.zerocases.com

ZERO CASES UK, LTD.

Unit 5, Alpha Park
Bevan Way, Smethwick | West Midlands B66 1BZ UK
Phone +44 (0) 121 558 2011 | Fax +44 (0) 121 565 2115
Email europesales@zerocases.com | Web www.zerocases.com